

# HD40-3 FOR PEGASUS 使用說明書



## 目次

1. 安全注意事項
2. 安裝說明
3. 控制面板按鍵說明
4. 參數區內容調整步驟
5. 常用參數列表



**寶欣全球售服網**  
 服務專線：+886-2-2676-5203  
 傳真：+886-2-2689-6600, 2689-3657  
 電子郵件：service@hohsing.com.tw  
 網址：http://www.hohsing.com

**中國地區**  
 服務專線：+86-21-64901024  
 傳真：+86-21-54570064  
 網址：http://www.hohsing.com



### EC 指令自我宣告書：

本公司在此宣告以下產品系列：  
 AC 何馬馬達-HD 系列

皆符合以下 EC 指令的規定：  
 -EC 低電壓指令 (2014/35/EU)  
 -EC 電磁兼容指令 (2014/30/EU)  
 -EC 機械指令 (2006/42/EC)

及配合相關安全標準如下：  
 EN 60204-31：機械之電機設備之安全。  
 EN 12100：機械安全- 基本概念，設計的一般原則。

### 有毒物質限量指令自我宣告書：

本公司在此宣告以下產品系列：  
 AC 何馬馬達-HD 系列

皆符合以下指令的規定：

1. 歐盟 RoHS 指令 (2002/95/EC)
2. 中華人民共和國電子行業標準：電子信息產品中有毒物質的限量要求 (SJ/T 11363-2006)

本公司產品本身(馬達、控制箱)或其包裝材料及附件(紙箱、螺絲配件包、說明書、貼紙、標籤、印刷品...等等)或其元件與原材供應商皆依照歐盟 RoHS 指令及中華人民共和國電子行業標準的限量規定而符合以下所列之六種有毒物質的限量要求：

有毒物質	限量要求
鉛 (Pb)	低於 240 ppm
汞 (Hg)	低於 800 ppm
鎘 (Cd)	低於 80 ppm
六價鉻 (Cr VI)	低於 800 ppm
多環聯苯 (PBB)	低於 800 ppm
多環二苯醌 (PBDE)	低於 800 ppm

- \* 基板的無鉛製程：總鉛含有濃度基準量 800 ppm 以下。
- \* 包裝材料：Pb+Hg+Cd+Cr VI 含有濃度基準總共合計 80 ppm 以下。

寶欣機械股份有限公司

廠長  
李春長先生

## 1. 安全注意事項：

使用前請詳閱本手冊與所搭配的縫紉機說明書，並請注意下列事項

- 安裝及操作須由受過正確訓練的人員來執行，拆卸安裝動作前請先關閉電源拔掉插頭並等待 5 分鐘。
- 本驅動裝置僅適用於指定範圍的縫紉機械，請勿移做其他用途。
- 電源電壓請遵照馬達與控制箱銘牌所標示之規格 ±10 % 範圍內操作。

**※注意：**控制箱電壓規格如為 AC 220V 時，請勿插接到 AC 380V 的電源插座上，否則將出現異常且馬達將無法動作。此時請立即關閉電源開關，重新檢查電源，持續供應 380V 超過五分鐘以上，將可能燒損電源輸入的保險絲及電解電容而危及人身安全。

- 請遠離高週磁波機器或電波發射器等，以免所產生的電磁波干擾本驅動裝置因而發生誤動作。
- 請不要在日光直接照射的場所、室外及室溫 45°C 以上或 5°C 以下的場所操作。
- 請不要在暖氣(電熱器)旁、有露水的場所及在相對濕度 30 % 以下或 95 % 以上的場所操作。
- 請不要在灰塵多的場所、具有腐蝕性物質的場所及有揮發性氣體的場所操作。
- 請注意不要被外物壓住或過度扭曲電源線。
- 為防止雜訊干擾或漏電事故，請做好接地工程。
- 在第一次開電後，請先以低速操作縫紉機並檢查轉動方向是否正確。
- 縫紉機運轉時，請不要去觸摸皮帶輪、天秤、針等會動作的部份。
- 所有可動作的部份，必須以所提供的防護裝置加以隔離，防止身體接觸並請勿在裝置內塞入其他物品。
- 修理及保養須由經過訓練的技術人員執行，而所有維修用的零件須由本公司提供或認可，方可使用。
- 請不要以不適當物體來敲擊或撞擊本產品裝置。

### 危險標示、注意標示

這個標示符號表示機器安裝時，如有錯誤恐會傷害到人體或機器會受到損壞，所以機器方面有危險性的地方會有此標示。

這個標示符號表示有高壓電，電氣方面有危險性的地方會有此標示。

### 保固期限

本產品保固期限為購買日期起一年內或出廠月份起 18 個月內。

### 保固內容

本產品在正常情況且無人為失誤的操作下，於保固期間無償的為客戶維修使能正常操作。但以下情況於保固期間將得以收取維修費用：

1. 不當使用包括連接高壓電源、將產品移做其它用途、自行拆卸、維修、更改、或不依規格範圍使用、進水進油及插入異物於本產品。
2. 火災、地震、閃電、風災、水災、鹽蝕、潮濕、異常電壓及其它天災或不當場所造成之損害。
3. 客戶購買後摔落本產品，或客戶自行運輸(或託付之運輸公司)所造成之損害。

\*本產品於生產及測試上皆盡最大努力和嚴格控管使其達到高品質及高穩定的標準，但外部之電磁或靜電干擾或不穩定的供應電源，仍可能對本產品造成影響或損害，因此操作場所的接地系統一定要確實做好，並建議客戶安裝故障安全防護裝置(如漏電電警)。

## 2. 安裝說明：

### HD 系列的安裝方式

將控制箱及控制箱鎖裝於車板下方。

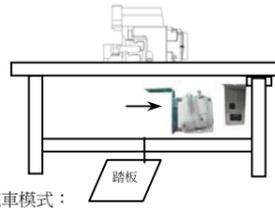

**注意：**  
 安裝及調整前請確定已關掉電源開關及拔掉插頭以利人身安全。

### 馬達的安裝

PEGASUS MX/EX/M900/M800 拷克車模式：

1. 將車頭的皮帶輪及散熱風葉卸下。
2. 將墊片放入車頭心軸後再放入馬達心軸。並利用端面螺絲迫緊馬達心軸。  
 注意：馬達心軸上紅點記號的 set 螺絲固定於車頭心軸平面或凹槽上。  
 安裝 EX 機種時，請將紅點處的 set 螺絲，更換為平頭模式的 set 螺絲。  
 安裝 M900/M800 機種時，請先套入心軸墊環，並利用端面螺絲迫緊墊環後，再組裝心軸。
3. 將組裝治具放入馬達本體後，馬達本體連同組裝治具套入馬達心軸上，再將馬達本體順著組裝治具推向車頭端面。將螺絲鎖緊固定後，再將組裝治具取出。注意：馬達心軸上黏著強力磁石，本體推向車頭平面注意強力磁石的吸引力，避免手指夾傷或馬達本體碰撞，造成損壞。組裝治具每安裝一台即報廢，不可以重複使用。
4. 將馬達手輪放入心軸並推至靠面後，鎖緊 set 螺絲及完成。  
 注意：鎖緊手輪前，先將車頭轉動至上定位點後，轉動手輪，使手輪端面圓點對準馬達本體記號後，固定手輪 set 螺絲。馬達運轉轉針時，即可停於針上位置。若停針位置不滿意，可放鬆手輪左右微調至滿意位置後固定即可。

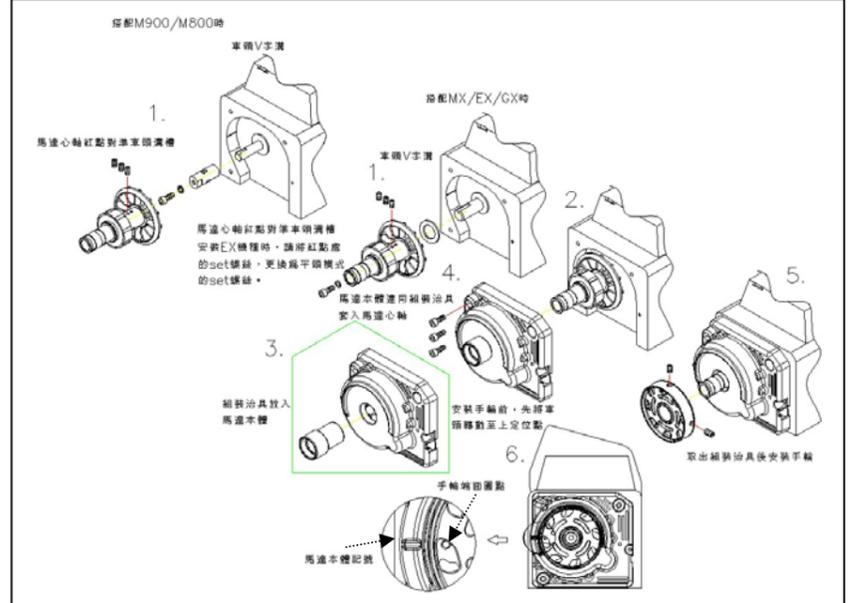

### 控速器的調整

調整需求	調整結果
1 踏板前踏力量的調整	當彈簧 A 愈向右側勾時，表示力量的愈重。 當彈簧 A 愈向左側勾時，表示力量的愈輕。
2 踏板後踏力量的調整	當螺絲 B 愈向上時，則後踏力量愈輕。 當螺絲 B 愈向下時，則後踏力量愈重。
3 踏板行程長短的調整	當吊桿 D 向右側孔鎖裝時，表示行程較長。 當吊桿 D 向左側孔鎖裝時，表示行程較短。

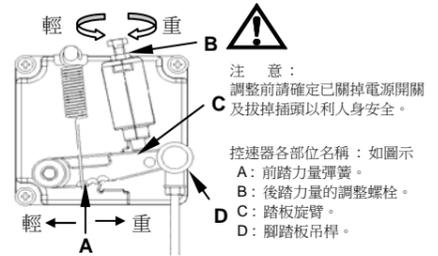

## 3. 控制面板按鍵說明：

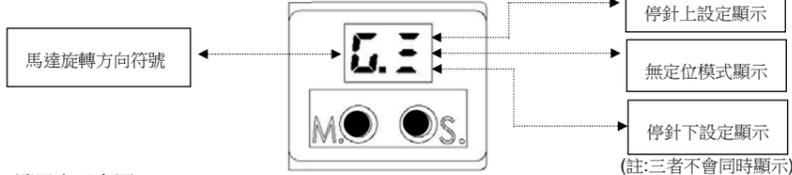

### 3.1 端子座示意圖

#### HD40-3

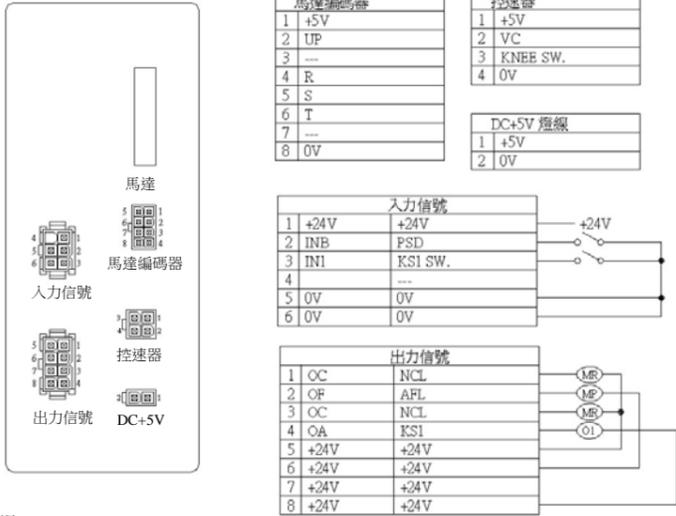

### 4. 參數區內容調整步驟：

- 如何進入參數內容調整內容
- 步驟一：按住 M 鍵後，則進入設定模式。
- 步驟二：按 M 鍵選擇欲調整的參數
- 步驟三：按 S 鍵進入數值調整模式。
- 步驟四：按 M 鍵可遞增數值。
- 步驟五：調整至欲設定之數值後，按 S 鍵進行儲存。

#### 4.1 如何設定針停位置(針上/針下)

按住 "● S."，並同時開啟電源。進入設定模式後以 "M ●" 選擇 UP (針上) / DN (針下)。按 "● S." 儲存。

### 5. 常用參數列表：

參數代碼	參數定義	調整範圍	單位	D0	D1	D2
				拷克車	拷克車 /TK	拷克車 /ASL
P0	H 最高回轉速	P1(L)-7500 spm	*100	50	50	50
P1	L 最低回轉速	300-500/P0(H) spm	*10	30	30	30
P2	SP 車縫速度顯示	Zero speed-Hi speed	*100	0	0	0
P3	SIN 單一信號定位器功能開啟	0/2	*1	0	0	0
P4	NU 單一信號定位器「針上」位準選擇	L/H	---	L	L	L
P6	POL 開電時第一針自動慢速功能開啟	ON/OFF	---	OF	OF	OF
P7	SLM 慢速起縫模式	T/A/OFF	---	OF	OF	OF
P8	S 起縫慢針速度	300-2000 spm	*100	4	4	4
P9	SLS 起縫慢針針數	1-99 stitches	*1	2	2	2
PA	DIR 馬達旋轉方向	CC/CW	---	CC	CC	CC
PB	SVC 啟動位準電壓	0-9	*1	0	0	0

參數代碼	參數定義	調整範圍	單位	D0	D1	D2
				拷克車	拷克車 /TK	拷克車 /ASL
PC	TVC 全後踏切線位置調整	0-9	*1	0	0	0
PD	HHC 半後踏取消抬腳功能	ON/OFF	---	OF	OF	OF
PE	FHC 全後踏取消切線功能	ON/OFF	---	OF	OF	OF
PZ	MAC 車頭碼選擇	D0-D2	---	D0	D1	D2
FL	FLOAD 回復出廠設定	Y/N	---	N	N	N
FS	FSAVE 儲存出廠設定	Y/N	---	N	N	N
BS	ASLB 前吸功能選擇	ON/OFF	---	OF	ON	ON
C1	ASLC1 前吸針數	0-99 stitches	*1	10	10	10
ES	ASLE 後吸功能選擇	ON/OFF	---	OF	ON	ON
C2	ASLC2 後吸針數	0-99 stitches	*1	35	35	35
DS	BDS 後吸延遲動作針數	0-20 stitches	*1	0	0	0
BT	TCB 前切功能選擇	ON/OFF	---	OF	OF	ON
C3	TCS1 前切針數	0-99 stitches	*1	8	8	8
ET	TCE 後切功能選擇	ON/OFF	---	OF	OF	ON
C4	TCS2 後切針數	0-99 stitches	*1	35	35	35
WS	WSUCM 節能吸功能	ON/OFF	---	ON	ON	ON
W1	WSUC1 節能吸開啟針數	0-99 stitches	*1	10	10	10
W2	WSUC2 節能吸關閉針數	0-990 stitches	*10	3	3	3
C8	SEN 電眼功能	ON/OFF	---	OF	ON	ON
C9	AS 自動縫速度設定	200-5000 spm	*100	20	20	20
CA	PSN 無加工物可車縫	ON/OFF	---	OF	OF	OF
CB	IBV 電眼動作信號	ON/OFF	---	OF	OF	OF
CC	CMS 電眼動作確認針數設定	0-99 stitches	*1	3	3	3
CD	AFL 結尾後自動抬腳	0-3	*1	0	0	0
CE	TFM 全後踏重置程序模式選擇	0-2	*1	0	0	0
CF	NIKT 切刀運動吸風時間	0-990 ms	*10	25	25	25
CG	SET 結尾完成自動結束	ON/OFF	---	ON	ON	ON
CH	SME 結尾車縫模式選擇	A/M	---	M	M	M
CI	MTC 手動切刀動作模式	ON/OFF	---	OF	OF	OF
CJ	STP 結尾完成自動停車	ON/OFF	---	OF	ON	ON
CK	TK3 切刀動作時間	10-990 ms	*10	10	10	10
CL	AFT 押腳自動下放時間	10-990 ms	*10	20	20	20
I1	IN1 IN1 輸入功能選擇	NO/TK/O/P	---	TK	TK	TK
IB	INB INB 輸入功能選擇	NO/PT/SO/SC	---	NO	PT	PT
IF	INF INF 輸入功能選擇	NO/F/TK	---	F	F	F
OA	OA OA 輸出功能選擇	NO/TK/AS/O/P/O/M	---	TK	TK	TK
OC	OC OC 輸出功能選擇	NO/NC/NW/AS/AW	---	NC	AW	AW

註：車頭碼調整方式  
 進入一階 PZ 參數，按 S 鍵顯示 A0 以明滅顯示按 M 鍵調整十位碼 A-E 按住不放，以數碼累加，直到放開 M 鍵停止累加，按 S 鍵調整個位碼 0-9 按住不放，以數碼累加，直到放開 S 鍵停止累加，如果 0.3 秒內沒再按鍵，即回復到正常畫面，自動儲存。

# HD40-3 FOR PEGASUS USER MANUAL



## CONTENTS

1. Safety Precaution
2. Installation
3. Panel Key Functions
4. Adjust step at parameter zone
5. General Parameter List



**H. S. Global Service Network**  
 SERVICE HOTLINE : +886-2-2676-5203  
 FAX : +886-2-2689-6600, 2689-3657  
 E-MAIL: service@hohsing.com.tw  
 WEBSITE: http://www.hohsing.com

**China Region**  
 SERVICE HOTLINE :  
 +86-21-64901024  
 FAX : +86-21-54570064  
 WEBSITE : http://www.hohsing.com



## EC Declaration of Conformity

We hereby declare that the following products:  
 AC servo motor—HD series  
 are in conformity with the provision of the EC directives as following:  
 -EC Low Voltage Directive (2014/35/EU)  
 -EC Electromagnetic Compatibility Directive (2014/30/EU)  
 -EC Machinery Directive (2006/42/EC)

Applied harmonized standards:  
 EN 60204-31 : Electrical equipment of industrial machines,  
 Particular requirements for sewing machines,  
 sewing units and sewing system.  
 EN 12100 : Safety of machines.

## Declaration of Conformity for Concentration Limits for Certain Hazardous Substances

We hereby declare that the following products:  
 AC servo motor—HD series  
 are complies with the following directives and requirements:  
 1. European Union RoHS Directive (2002/95/EC) and the concentration limits for certain hazardous substances (2005/618/EC)  
 2. People's Republic of China Electronic Business Standard : Requirements for concentration limits for certain hazardous substances in electronic information products (SJ/T 11363-2006)

Hazardous Substance	Permissible Values
Lead (Pb)	Less than 240 ppm
Mercury (Hg)	Less than 800 ppm
Cadmium (Cd)	Less than 80 ppm
Hexavalent chromium (Cr VI)	Less than 800 ppm
Polybrominated Biphenyl (PBB)	Less than 800 ppm
Polybrominated Diphenyl ether (PBDE)	Less than 800 ppm

\*The concentration of lead in the lead-free process for PCB shall be less than 800 ppm.  
 \*For packing materials shipped with our products or parts, the hazardous substances shall be 80 ppm or less in sum of Pb+Hg+Cr+VI.

H. S. Machinery. Co., Ltd.

Mr. C. C. Lee  
 Plant Manager

## 1. Safety Precaution :

Please read this manual with sewing machine manual thoroughly and pay attention for the following safety precaution.

- Installation and operation must be done by the trained personnel, also turn off the power switch and remove the plug from outlet and wait for 5 minutes before any installation.
- This product is designed for the specific sewing machines and must not be used for other purposes.
- Only use the power voltage as described on the name plate of the motor and control box in ±10 % ranges.

**Attention :** If the control box is AC 220V system, please don't connect to the AC 380V power outlet, otherwise the error will occur and motor is not functional. If that happened, please turn off the power switch immediately and check the power voltage. Continue supply the 380V power over 5 minutes might damage the fuses and burst the electrolytic capacitors and even might endanger the person safety.

- In order to prevent abnormal operation, keep the product away from the high frequency machines.
- Don't operate in direct sun light - outdoors area and the room temperature is 45°C above or 5°C under.
- Don't operate near the heater - dew area and the humidity is 30 % less or 95% more.
- Don't operate in dusty - evaporate - combustible gas area, and stay away from corrosive material.
- Don't apply heavy objects or excessive force on the power cord, also don't bend or pull the power cord.
- In order to prevent the static interference and current leakage, all grounding works must be done properly.
- After power on the machine for the first time, use low speed to operate and check the correct rotation direction.
- During machine operation, don't touch any moving parts.
- All moving parts must have protective device to avoid the body contact and objects insertion.
- Maintenance and repair must be done by the properly trained technician, also all the spare parts for repair must be approved or supplied by the manufacturer.
- Don't use any objects or force to hit or ram the product.

## Danger and caution signs

Risks that may cause personal injury or risk to the machine are marked with this symbol in the instruction manual.

This symbol indicates electrical risks and warnings.

## Limited Warranty

Warranty period of this product is 1 year from purchasing, or 18 months from our manufacturing date.

## Warranty Detail

Any trouble found within warranty period under normal use condition in conformance with this manual, it will be repaired free of charge. Repair will be chargeable in the following cases even if within warranty period:

1. Inappropriate use include: wrong connecting high voltage, wrong application, disassemble, repair, modification by incompetent personnel, or operate the product without the precaution, or operate the products out of its specification range. Insert odd objects or liquids into the product.
2. Damage by fire, Earth quake, lightning, wind, flood, salt corrosive, moisture, abnormal power voltage and any other damage cause by the natural disaster or by the inappropriate environments.
3. Dropping after purchase, or damage in transportation by customer himself. (or by customer's shipping agency)

Note : We put our best effort and mind in testing and manufacturing for assuring the quality and reliable of this product. But it is possible this product can still be damaged due to external magnetic interference and electronic static or noise or unstable power source more than expected; therefore the grounding system of operate area must be well-connected to this product and it's also recommended to install a failsafe device. (such as residual current breaker).

## 2. Installation:

### HD installation

Mounts speed control unit and control box

under the sewing machine table.

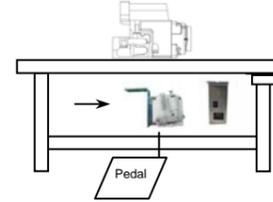

Caution :  
 For person safety, turn off the power switch and remove the power plug from outlet before any adjustment.

### Motor Installation

PEGASUS MX/EX/M900/M800 Overlock Mode:

1. Take off the pulley of sewing machine, remain the exhaust fan.
2. Put washer into the shaft of sewing machine then put it in the shaft of motor, to use screw to screw tight the shaft of the motor.

Note: The red mark on motor to fix on the shaft of sewing machine by set screw.

Plases change set screw on red dot to flat head set screw if installs EX machine.

Plases insert shaft washer priority and uses screw to tight up the washer then assemble the shaft while installs M900 M800 machine.

3. Put a fixture to motor then set into motor shaft, push motor to sewing machine end face by a fixture.

Note: Motor shaft sticking strong magnet, plases pay attention to powerful magnetic while force motor to sewing machine to avoid damage the motor or hurt your finger. Plases throw away the assemble tooling after assembled one machine. It is prohibit to use assemble tooling repeat.

4. Put motor pulley to motor shaft then tighten the screw. Note : Plases turn the sewing machine to up position before tighten the pulley and fix the set screw on the pulley. After that the needle at up position while motor is stop running. Plases release the pulley to process micro adjustment on pulley if the needle stop position is not satisfied.

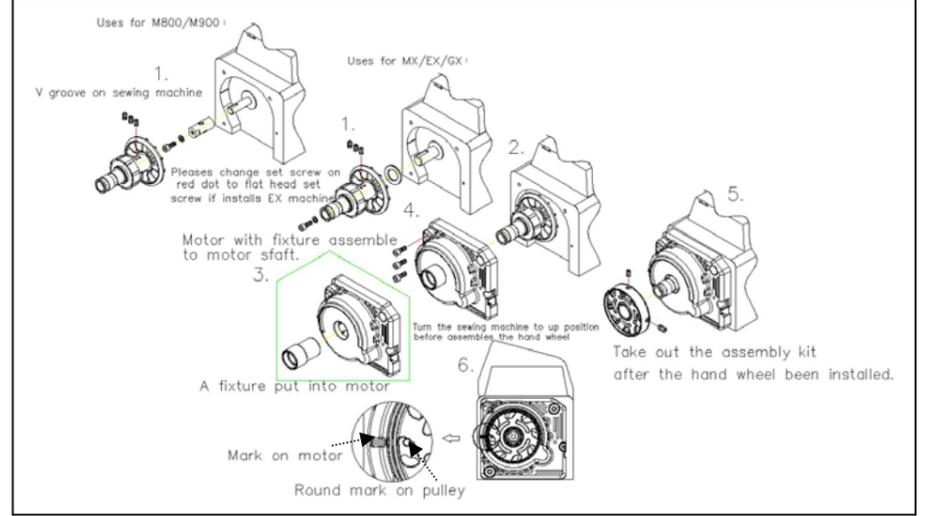

## Speed Control Unit adjustment

	Term of adjustment	Adjustment result
1	Toeing forward force adjustment	Spring A move to right = force increased Spring A move to left = force decreased
	Heeling backward force adjustment	Bolt B turn ↻ = force decreased Bolt B turn ↻ = force increased
3	Pedal stroke adjustment	Rod D secure at right = stroke is longer Rod D secure at left = stroke is shorter

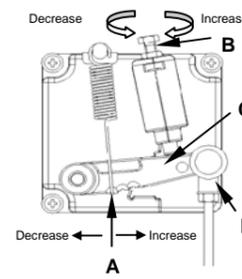

Caution :  
 For person safety, turn off the power switch and remove the power plug from outlet before any adjustment.

Components of speed control unit : see figure

A: Spring for toeing forward force adjustment  
 B: Bolt for heeling backward force adjustment  
 C: Pedal arm  
 D: Pitman rod for pedal

## 3. Panel Key Functions :

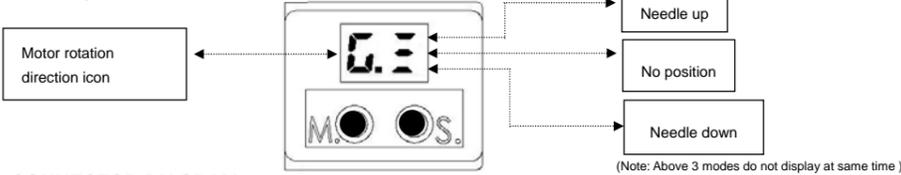

### 3.1 CONNECTOR DIAGRAM:

HD40-3

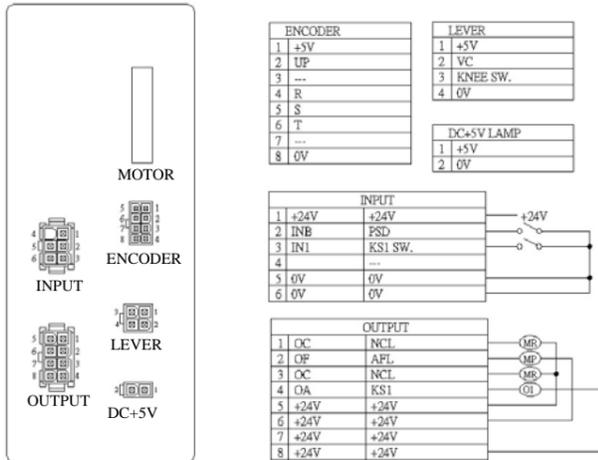

## 4. Adjust step at parameter zone:

- Step1: Press "M." key to enter setting mode.
- Step2: Press "M." key select the parameter you want to adjust.
- Step3: Press "S." key enter the parameter value adjustment.
- Step4: Press "M." key increase the value.
- Step5: Press "SET" key to save.

### 4.1 How to set needle position while fixed the synchronizer :

Press the " S. " key. Enter the setting mode , press "M. S. " key To select UP / DOWN , press " S. " key to save.

## 5. General Parameter List :

Parameter NO.	Function Name	Range	Ratio	D0	D1	D2
				Overlock	Overlock /TK	Overlock /ASL
P0	H	Maximum sewing speed	P1(L)-7500 spm	*100	50	50
P1	L	Low speed	300-500/P0(H) spm	*10	30	30
P2	SP	Sewing speed	Zero speed-Hi speed	*100	0	0
P3	SIN	Single positioning signal synchronizer	0/2	*1	0	0
P4	NU	Define the UP positioning signal mode H/L	L/H	---	L	L
P6	POL	Slow start setting for fist stitch sewing when the power ON	ON/OFF	---	OF	OF
P7	SLM	Slow start operation mode	T/A/OFF	---	OF	OF
P8	S	Slow start speed	300-2000 spm	*100	4	4
P9	SLS	Stitch numbers for slow start	1-99 stitches	*1	2	2
PA	DIR	Direction of motor rotation	CC/CW	---	CC	CC
PB	SVC	Pedal start stroke position adjustment	0-9	*1	0	0

Parameter NO.	Function Name	Range	Ratio	D0	D1	D2
				Overlock	Overlock /TK	Overlock /ASL
PC	TVC	Pedal trimming stroke position adjustment	0-9	*1	0	0
PD	HHC	Cancel foot lifting at half-heeling pedal	ON/OFF	---	OF	OF
PE	FHC	Cancel trimming at full-heeling pedal	ON/OFF	---	OF	OF
PZ	MAC	Machine code	D0-D2	---	D0	D1
FL	FLOAD	Factory default load	Y/N	---	N	N
FS	FSAVE	Factory default save	Y/N	---	N	N
BS	ASLB	Front suction function selection	ON/OFF	---	OF	ON
C1	ASLC1	Front suction stitches setting	0-99 stitches	*1	10	10
ES	ASLE	Rear suction function selection	ON/OFF	---	OF	ON
C2	ASLC2	Rear suction stitches setting	0-99 stitches	*1	35	35
DS	BDS	Setting stitches of delay rear suction	0-20 stitches	*1	0	0
BT	TCB	Front cutter function selection	ON/OFF	---	OF	ON
C3	TCS1	Setting stitches of front cutter	0-99 stitches	*1	8	8
ET	TCE	Rear cutter function selection	ON/OFF	---	OF	ON
C4	TCS2	Setting stitches of rear cutter	0-99 stitches	*1	35	35
WS	WSUCM	Air saving function selection	ON/OFF	---	ON	ON
W1	WSUC1	Setting valid stitches of suction for air saving	0-99 stitches	*1	10	10
W2	WSUC2	Setting invalid stitches of suction for air saving	0-990 stitches	*10	3	3
C8	SEN	Edge sensor function selection	ON/OFF	---	OF	ON
C9	AS	Automatic sewing speed	200-5000 spm	*100	20	20
CA	PSN	Re-start function at emergency stop	ON/OFF	---	OF	OF
CB	IBV	PSN logic signal invert	ON/OFF	---	OF	OF
CC	CMS	Edge sensor signal check	0-99 stitches	*1	3	3
CD	AFL	After real section auto foot lifting mode selection	0-3	*1	0	0
CE	TFM	When sensor detect the fabric, full heeling pedal mode selection	0-2	*1	0	0
CF	NIKT	Tape cutter link air saving off delay time	0-990 ms	*10	25	25
CG	SET	Trimming mode at sensor stop	ON/OFF	---	ON	ON
CH	SME	Mode selection for [C2. ASLC2] Stitches sewing	A/M	---	M	M
CI	MTC	Define the fabric protection function, when sensor detect the fabric	ON/OFF	---	OF	OF
CJ	STP	Restart section function select	ON/OFF	---	OF	ON
CK	TK3	Tape cutter action time	10-990 ms	*10	10	10
CL	AFT	The edge sensor command foot lifting turn off time	10-990 ms	*10	20	20
Power On + S Key	I1	IN1	IN1 Input function select	NO/TK/OP	---	TK
	IB	INB	INB Input function select	NO/PT/SO/SC	---	NO
	IF	INF	INF Input function select	NO/F/TK	---	F
	OA	OA	OA Output function select	NO/TK/AS/OP/OM	---	TK
	OC	OC	OC Output function select	NO/NC/NW/AS/AW	---	NC

NOTE:

Selected machine code Enter "PZ" PARAMETER , press S . KEY and hold it to adjust digit 0-9.

Violators will be prosecuted