



TENSION TYPE COMPUTERIZED METERING COUNTER DEVICE

OPERATION MANUAL



MODEL : TC 3



ENGLISH

賀欣全球售服網 / H. S. MACHINERY CO., LTD.

服務專線 / SERVICE HOTLINE : +886-2-2676-5203

傳真 / FAX : +886-2-2689-6600, 2689-3657

電子郵件 / E-MAIL : service@hohsing.com.tw

網址 / WEBSITE : <http://www.hohsing.com>

中國地區 (CHINA)

服務專線 : +86-21-64908325

傳真 : +86-21-54570064

網址 : <http://www.hohsing.com>

Contents

1. Installation	2
1-1. Connections of control box	3
1-2. Connector diagram	4
2. Adjustments	5
2-1. Adjusting the feeding shift of tape	5
2-2. Adjusting the sensitivity of sensor	6
3. Boot page	7
4. Sewing operation mode	7
4-1. Sewing mode	7
4-2. Step data setting	8
4-3. Left side menu and right side menu	13
5. Testing mode	15
5-1. Driven roller test	15
5-2. Untangling device setting mode	16
5-3. Thickness detecting mode	17
5-4. Accessory test	17
6. Parameter setting mode	19
6-1. Restore default setting	20
6-2. Setting needle Up/Down position at machine stop	21
7. USB upload/download	21
8. Operation instruction	24
9. Prompt code and error code	31
9-1. Prompt code	31
9-2. Error code	32

1. Installation

TC3-U Upper Feeder

Untangling Device

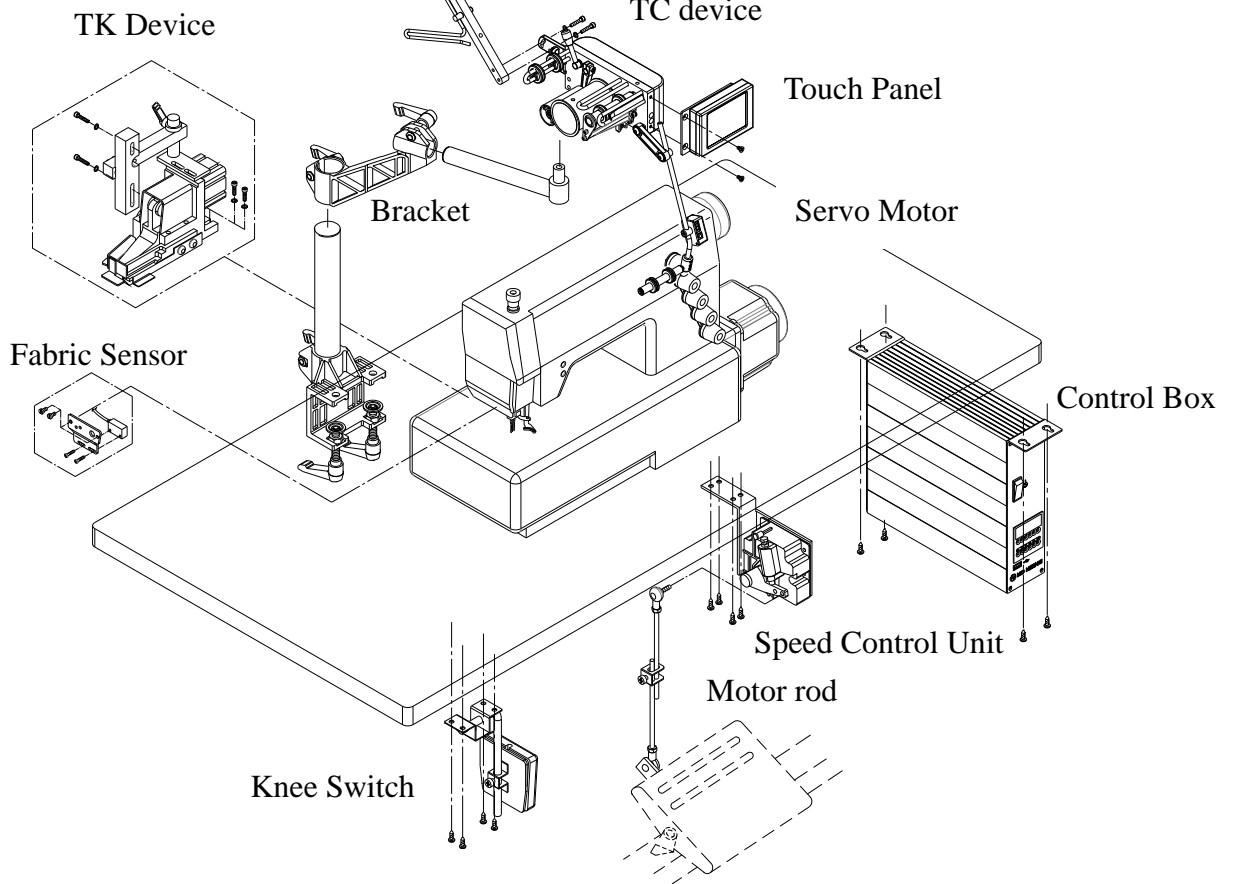

TC3-B Down Feeder

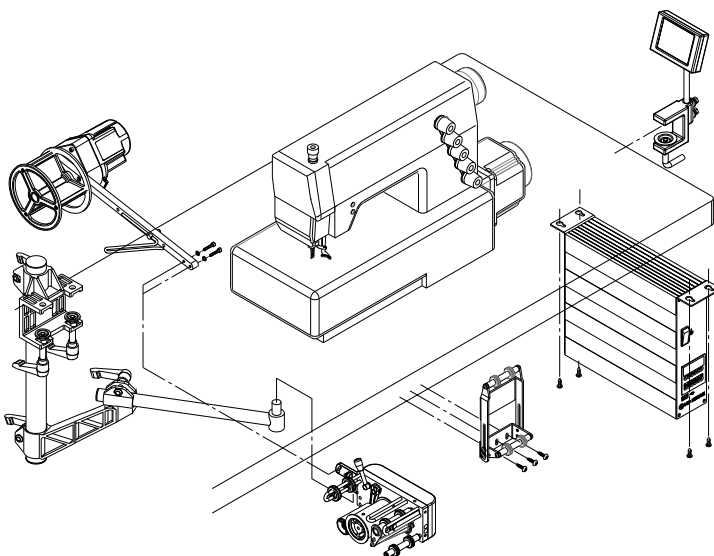

TC3-S Side Feeder

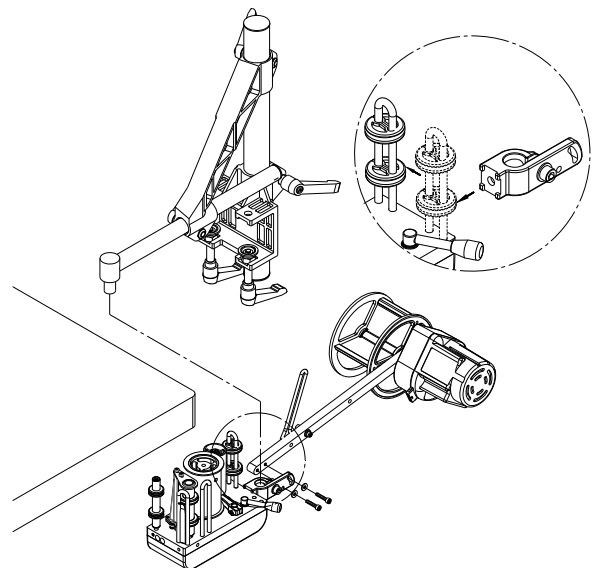

1-1. Connections of control box



CAUTION

1. Only the authorized technicians are allowed to conduct the cable connections.
2. Always turn the power off and unplug the power cord before conducting or checking the connections.

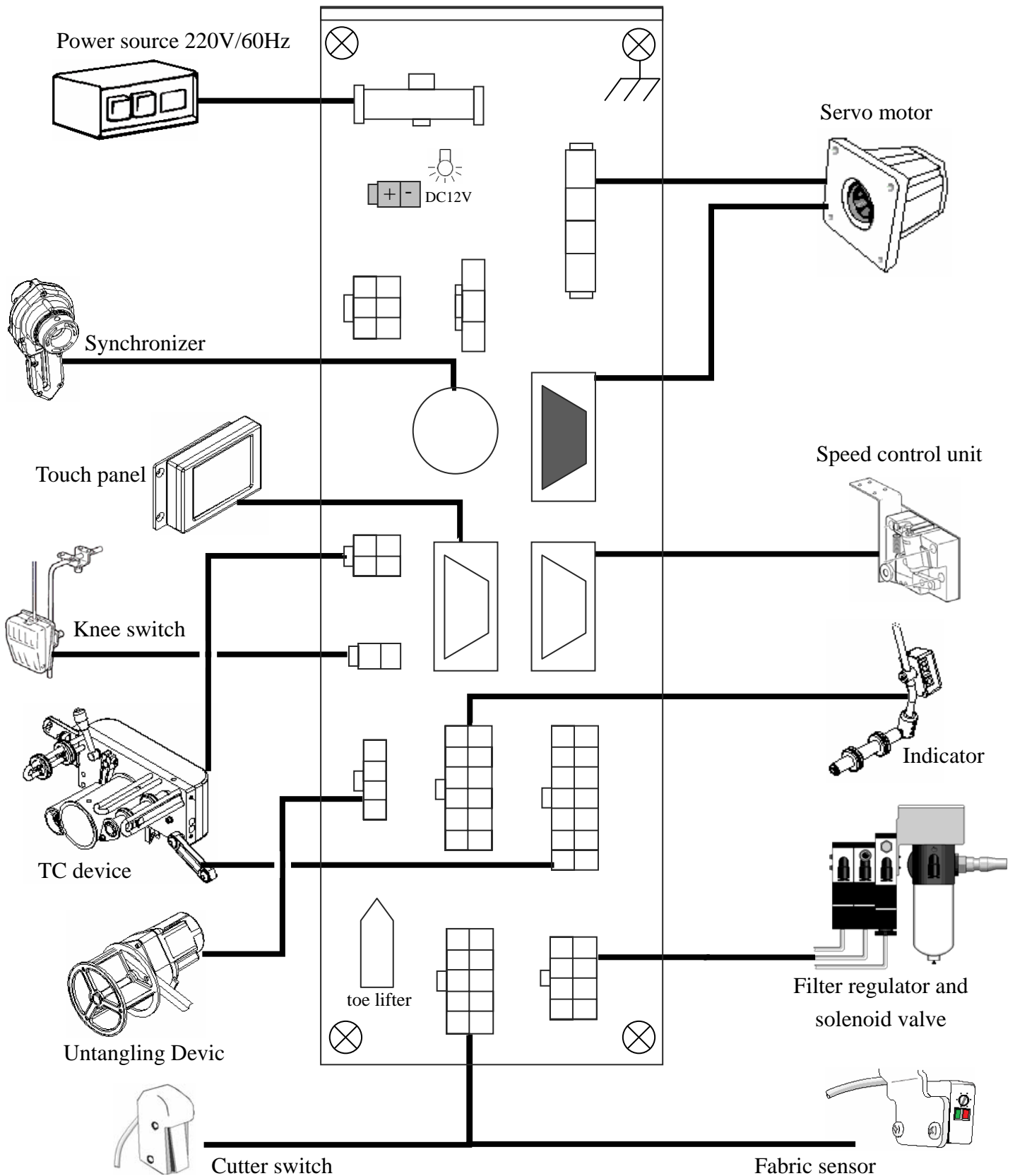

1-2. Connector diagram

X4-OPTION		
1	+5V	+5V
2	TK SENSOR	TK SENSOR
3	0V	0V
4	M SENSOR	M SENSOR
5	+12V	+12V
6	TK SW.	TK SW.
7	0V	0V
8	SAFETY SW	TK SAF. SW
9	+24V	+24V
10	AFL	AFL

X5-AC MOTOR	
1	P1
2	P2
3	P2_C
4	EARTH

X6-OUTPUT2	
1	+24V
2	---
3	MC_OPEN

KNEE SW.	
1	0V
2	INF

X8-STEPPING MOTOR	
1	A
2	B
3	C
4	D
5	E
6	---

X7-DC MOTOR	
1	---
2	---
3	DC-A
4	DC-B

TENSION SW.	
1	+5V
2	TENSION SW.
3	0V

ENCODER	
1	+5V
2	UP
3	DOWN
4	A PHASE
5	B PHASE
6	R
7	S
8	T
9	0V

OPERATION BOX	
1	+12V
2	---
3	T1out
4	R1in
5	---
6	---
7	T2out
8	R2in
9	0V

SYNCHRONIZER	
1	---
2	+5V
3	DOWN
4	0V
5	NO SYNC.
6	---
7	UP
8	ENC

LEVER	
1	+12V
2	START
3	VC
4	FRONT
5	VC1
6	BACK
7	KNEE SW.
8	TM
9	0V

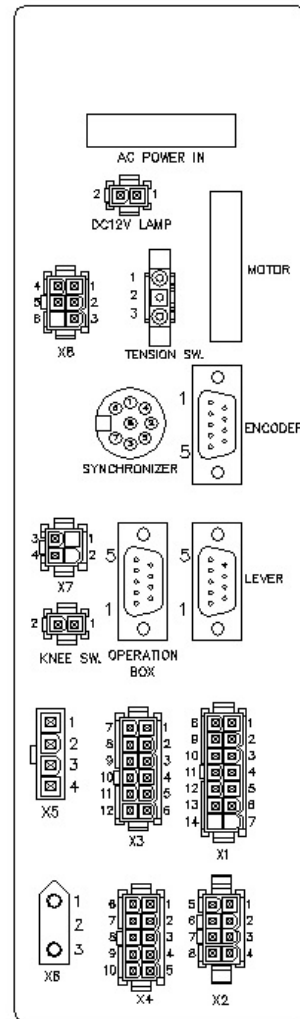

DC+12V LAMP	
1	0V
2	+12V

X1-LOAD CELL	
1	+12V
2	SPI_SDO
3	SPI_SCK
4	SPI_SDI
5	SPI_CSN
6	0V
7	---
8	+12V
9	HALL_SDA
10	POS1
11	POS2
12	HALL_SCL
13	0V
14	---

X2-OUTPUT1	
1	ASL
2	NCL
3	ML_OUT
4	MP_OUT
5	+24V
6	+24V
7	+24V
8	+24V

X3-SEVEN SEGMENT	
1	+5V
2	SEG A
3	SEG B
4	SEG C
5	SEG D
6	SEG E
7	SEG F
8	SEG G
9	SEG H
10	IN2
11	0V
12	0V

2.Adjustments

2-1.Adjusting the feeding shift of tape

If the auxiliary roller is not parallel to the driven roller, the tape will be misaligned to the right or the left. To correct the misalignment, loosen screw A on the roller shaft, and turn the roller shaft screw B until the tape feeds straight and aligns perfectly.

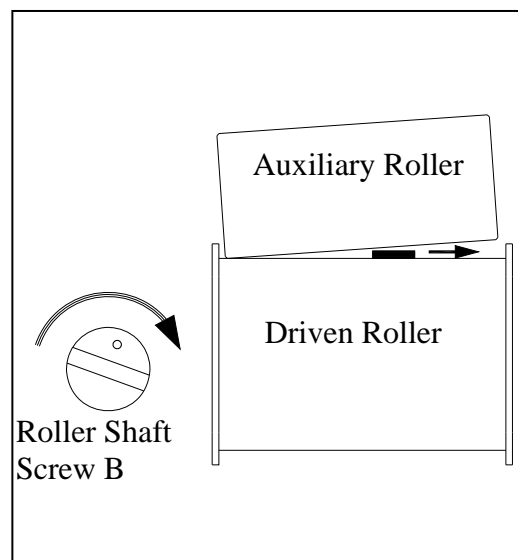
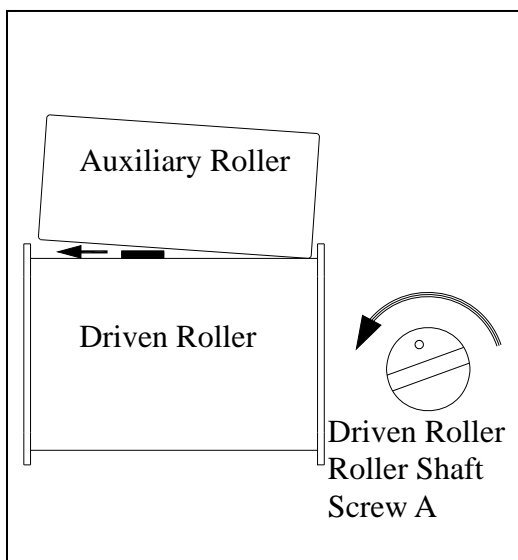
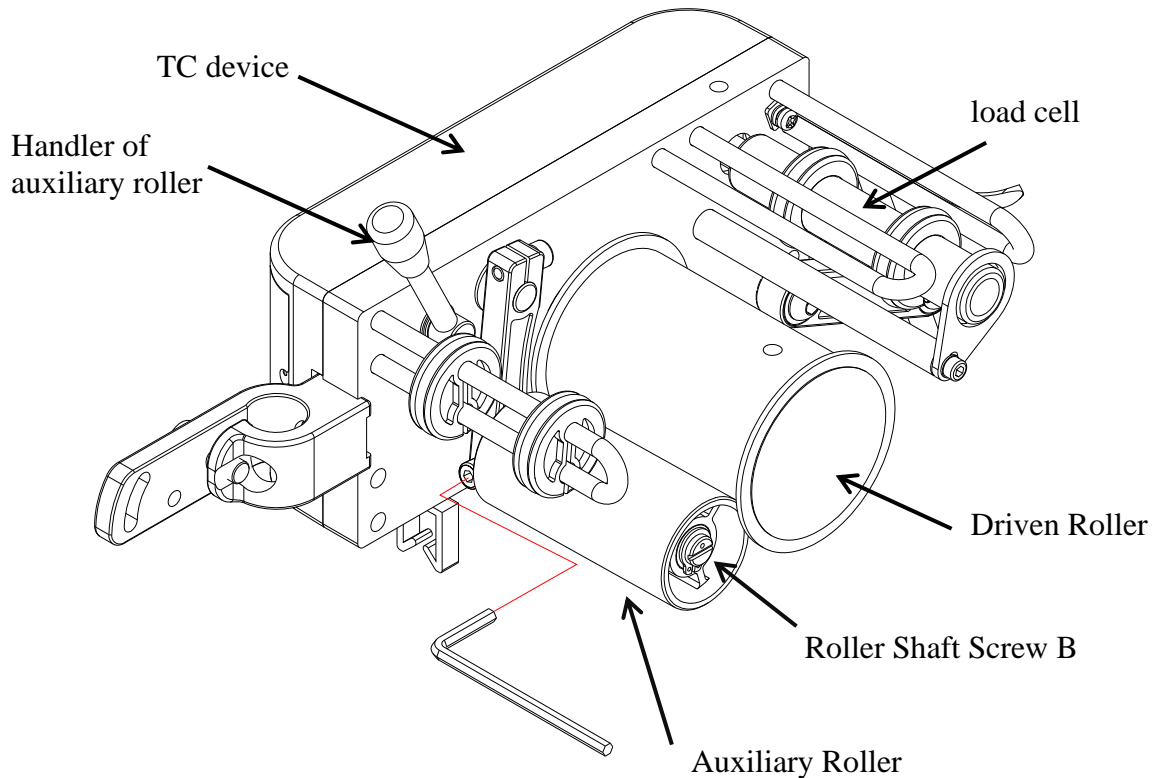

2-2.Adjusting the sensitivity of sensor



CAUTION

1. The tape cutter could be activated unexpectedly and it could be dangerous; therefore, no sewing work is allowed before an authorized technician finishes the sensitivity adjustment of fabric sensor.
2. The sensitivity of fabric sensor can only be conducted during the system power ON.
Safety precaution must be taken to avoid the accident caused by the machine running unexpectedly.
3. Malfunction may occur when the reflector on the top surface of the needle plate is not clean.
Ensure to keep the reflector clean.

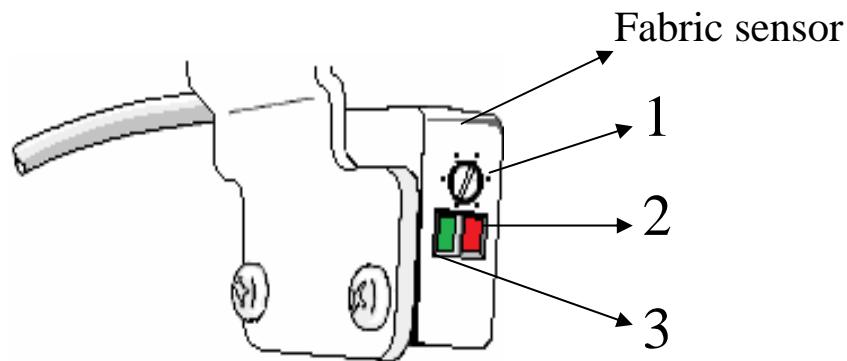

1. Turn the sensitivity adjustment Dial 1 of fabric sensor fully counterclockwise.
2. Turn the sensitivity adjustment Dial 1 clockwise slowly until both Light 1(red) and Light 2(green) are on.
3. Place a fabric under the fabric sensor, and check if Light 3(green) is still on while Light 2(red) is off. If Light 2(red) is on, turn the sensitivity adjustment Dial 1 counterclockwise slowly until Light 2(red) turns off.

3.Boot page

















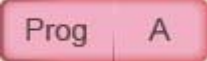

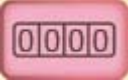
1. Main software Ver. xxx.yyy
Displays the current operating software version.
2. Touch panel Ver. xxx
Displays the software version of the touch panel.

4. Sewing operation mode

4-1. Sewing mode



Icon	Description
	Lock key at left side menu: 1. Press  to lock menu. 2. Press  then key in a correct password to unlock. 3. Functions on the left side menu are prohibited when it is locked.
	Press to pull down menu on the left/right side(please refer to 4-3)
	Fabric detected indication (No function without sensor), LED on: detected, LED off: not detected.

Icon	Description
	Press to change the sewing program no. Maximum of 9 sewing programs. A ~ I.
	stitch number: Press to copy the current display stitch number to the stitch field of the working sewing step.
	Piece counter, press and hold for 3 seconds to reset the counter. (to display or hide the piece counter please refer to 4.3)
 987	Free to change tension control:  with tension control,  free tension control. The tension-free value is displayed below the key. Press the Tension-free key for 2 seconds to adjust the tension-free value.
	Step selector, press to move the selection bar.
	Step number: 1. Displays the Step number. 2. Press to activate TK setting, to set the stitch number of tape cut at start and end (please refer to 4-2 Step9)
	Press to adjust sensitivity. (please refer to 4-2)
	Press to set the stitches of current step. (please refer to 4-2)
	Press to adjust the tension range. (please refer to 4-2)
	Press to select Sewing mode. (please refer to 4-2)



4-2. Step data setting

Step 1. Press  to edit the Program A~I.

Step 2. The selection bar displays on the Step 1. Press  to pop up the keyboard.



Step 3. Enter the required tension value. Then press the  to save the value and to close the keyboard.

Note: 1. Tension values range from 1 to 999. The smaller the value, the tighter the tension.
2. Press <Free> to set the free tension value.

Step 4. If the tape vibrates, press **Sen.** to set the sensitivity of the tape.

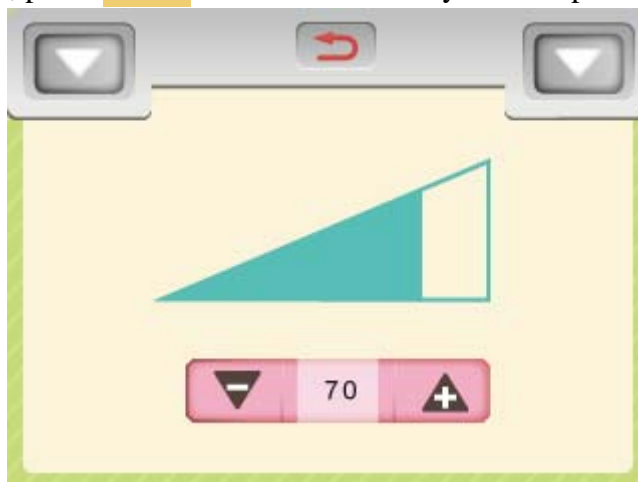

Step 5. Reduce the value of the sensitivity until the vibration disappears. Then press  to return to the sewing mode.

NOTE: As long as the vibration of tape disappears, the larger the value of sensitivity, the more accurate the control of tension.

Step 6. Press **Mode** to select Sewing mode A, M, As, Aa or END.

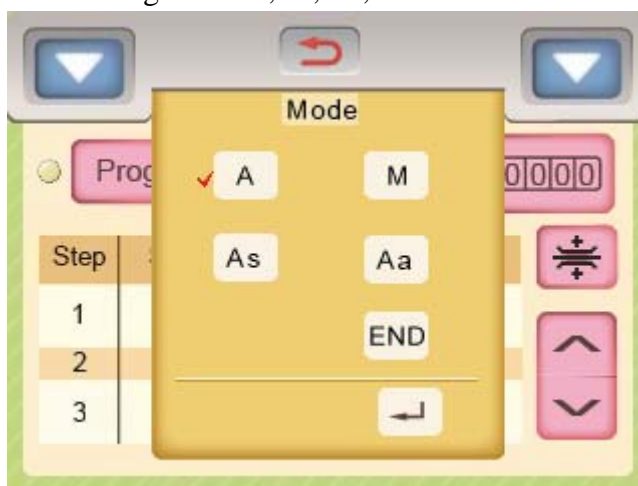

NOTE:

6-1.Sewing mode selection:

A (automatic): The sewing steps of programs will run automatically and the stitches of steps will be completed sequentially as settings.

M (manual): The sewing steps of programs will run manually by an external Step change switch.

As (automatic2): The stitch counter of sewing steps will not count up unless a fabric is detected.

Aa (automatic sewing mode): The stitches of steps and programs will run automatically and the stitch counter of sewing steps will not count up unless a fabric is detected.

END (ending mode): Ends the current sewing program and prohibits sewing

stitches in this step.

6-2. Setting the END mode in Step 1 is not allowed.

6-3. Press  to save the settings and back to the Sewing mode.

6-4. Press  to cancel the settings and back to the Sewing mode.

Step 7. The number of stitches must be entered when the sewing mode A, As or Aa is selected. Please press  to pop up the keyboard.



Step 8. Enter the required the number of stitches, press Stop to display the number of stitches and additional 's' that machine stops immediately when the setting stitches are completed and the next sewing Step can start to run by toeing down the pedal unless the pedal returns to neutral position in advance.

Press  to return to the Sewing mode.

Step 9. Press the number of Step to enter TK settings.

NOTE: The function is valid only for the sewing machine equipped with TK device.



Description of setting:

1. Set the number of stitches for the front TK, the rear TK, and the rear Stop respectively.

Example:

 Front TK: Cut the tape after 10 stitches sewed on the fabric tape.

R✂ Rear TK: Cut the tape after the sensor detected the fabric tape and 15 stitches sewed on it.

Rs Rear Stop: Stop the machine after the sensor detected the fabric tape and 15 stitches sewed on it.

The setting page:

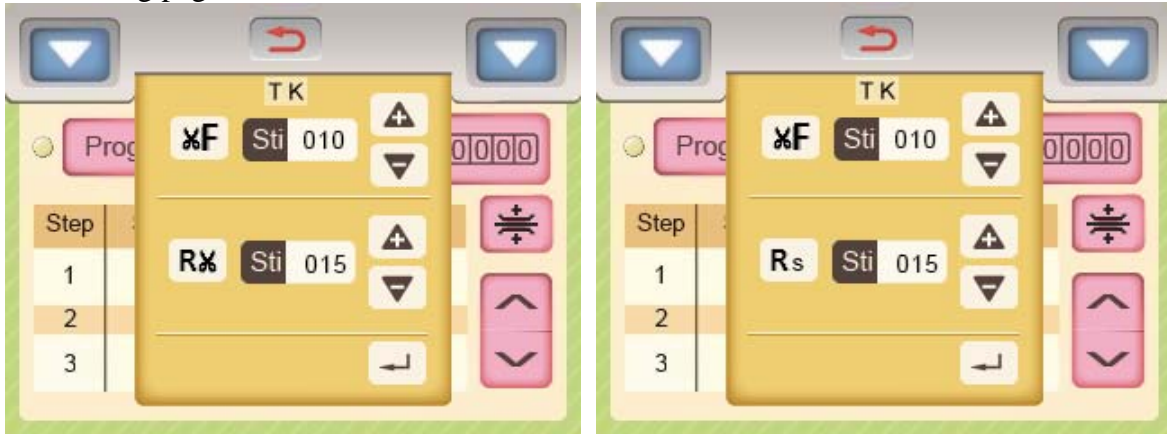

- ✂ shows in front of Step number when Front TK mode is selected. It appears in back of Step number when Rear TK mode is chosen. 'S' appears in back of Step number when Rear Stop mode is set.

Step	Sen.	Stitch	Ten.	Mode	
✂ 1	70		800	M	Front tape cutter
2 ✂	70	80	700	A	Rear tape cutter
✂ 3 s	70		800	M	Front tape cutter & Rear Stop function engaged

Step 10. Set all settings of Steps required for the corresponding Program (A~I) according to the instruction described in the procedure Step 1-9; finally, set the last Step as END mode.

Example:

Step 1: Sensitivity:70, Tension:800, Mode:M

Step 2: Sensitivity:70, Stitches:80, Tension:700, Mode:A

Step 3: Mode:END

Setting data as shown:

Step	Sen.	Stitch	Ten.	Mode
1	70		800	M
2	70	80	700	A
3				END

Step 11. The maximum number of Steps in one Program (A~I) is 8. In case of 13 Steps designed, the Step 9 in Program A allows you to continue the Steps to the next Program (Program B) by setting the Step 9 in Program A with the data "goto B" as shown below.

The system allows you to design a maximum number of 27 Steps in total for a specific project.

Example:



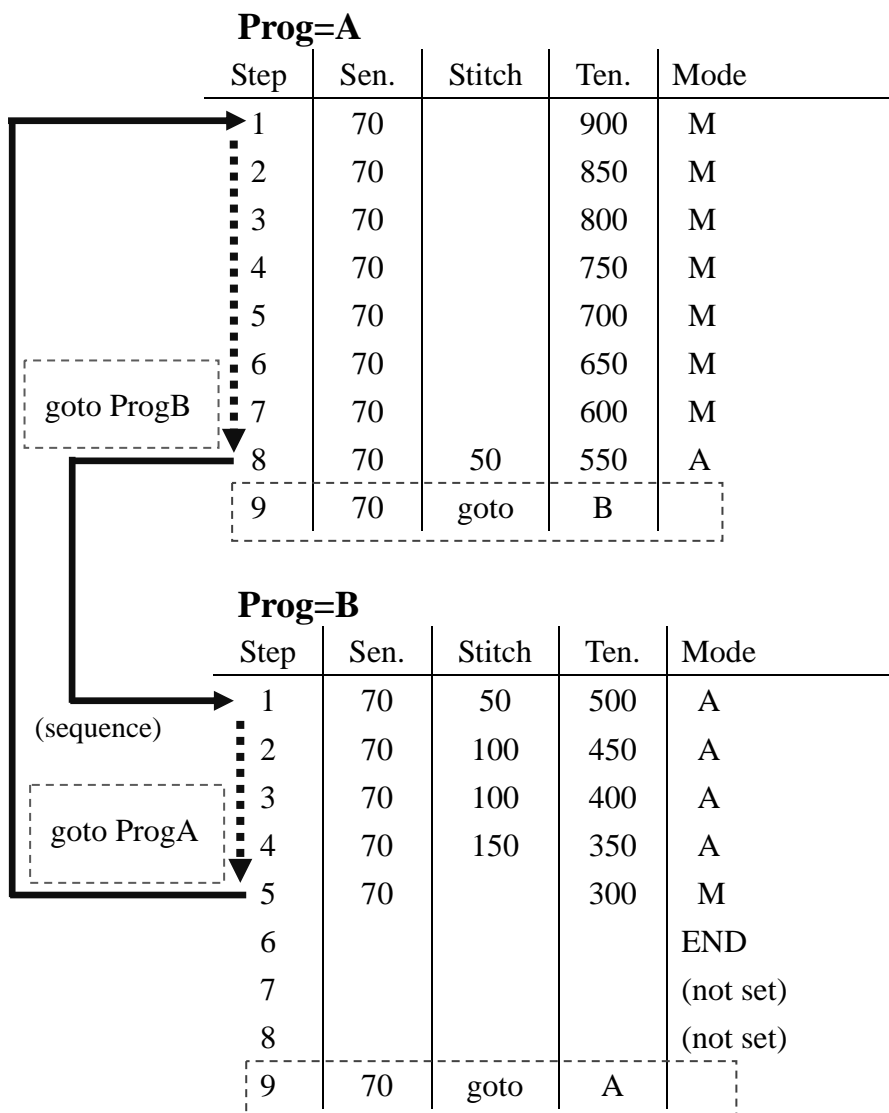

- step 1: Sensitivity:70, Tension:900, Mode:M
- step 2: Sensitivity:70, Tension:850, Mode:M
- step 3: Sensitivity:70, Tension:800, Mode:M
- step 4: Sensitivity:70, Tension:750, Mode:M
- step 5: Sensitivity:70, Tension:700, Mode:M
- step 6: Sensitivity:70, Tension:650, Mode:M
- step 7: Sensitivity:70, Tension:600, Mode:M
- step 8: Sensitivity:70, Stitches:50, Tension:550, Mode:A
- step 9: Sensitivity:70, Stitches:50, Tension:500, Mode:A
- step 10: Sensitivity:70, Stitches:100, Tension:450, Mode:A
- step 11: Sensitivity:70, Stitches:100, Tension:400, Mode:A
- step 12: Sensitivity:70, Stitches:150, Tension:350, Mode:A
- step 13: Sensitivity:70, Tension:300, Mode:M





Setting data in Program A and B as shown:



4-3. Left side menu and right side menu



Left side menu	
	Press to pull down the left side menu
	Press to enter the parameter setting mode
	Press to enter the testing mode
	USB upload/download

Right side menu	
	Press to pull down right side menu
	Start/stop the tape feeding device
	Press to display/hide the piece counter.
	Group selection

NOTE: You can use left side menu when  is shown.

4-3-1.  Start/stop the tape feeding:

Start: Stops tension control and untangling device for tape insertion or maintenance.

Stop: Start tension control and untangling device.

4-3-2.  Display/hide the piece counter.

4-3-3.  Group selection:

There are 9 selectable groups. Each group consists of 9 Programs (A~I) and each Program allows you to design 8 steps. Group selection page is shown as below.

Group selection page:

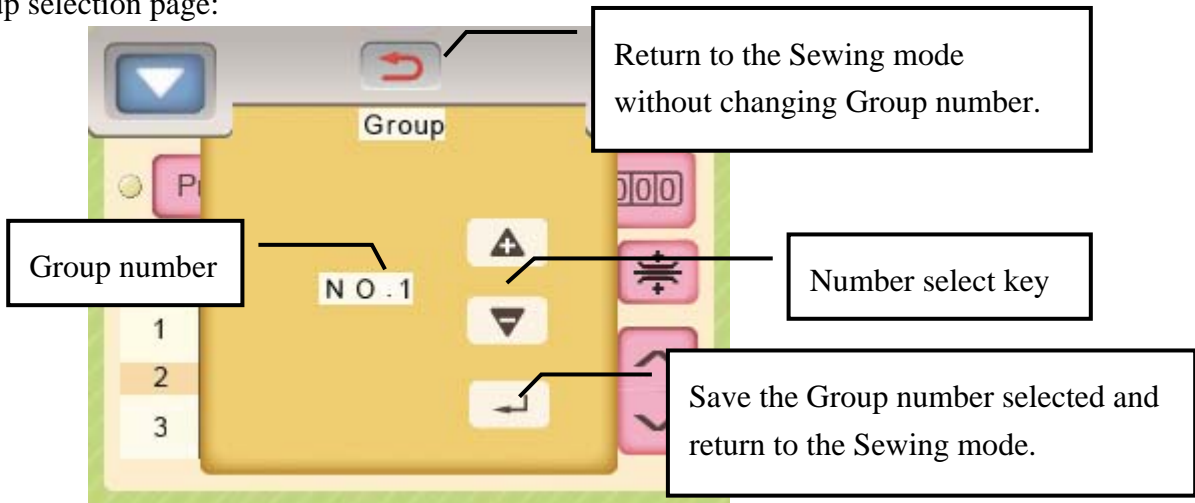



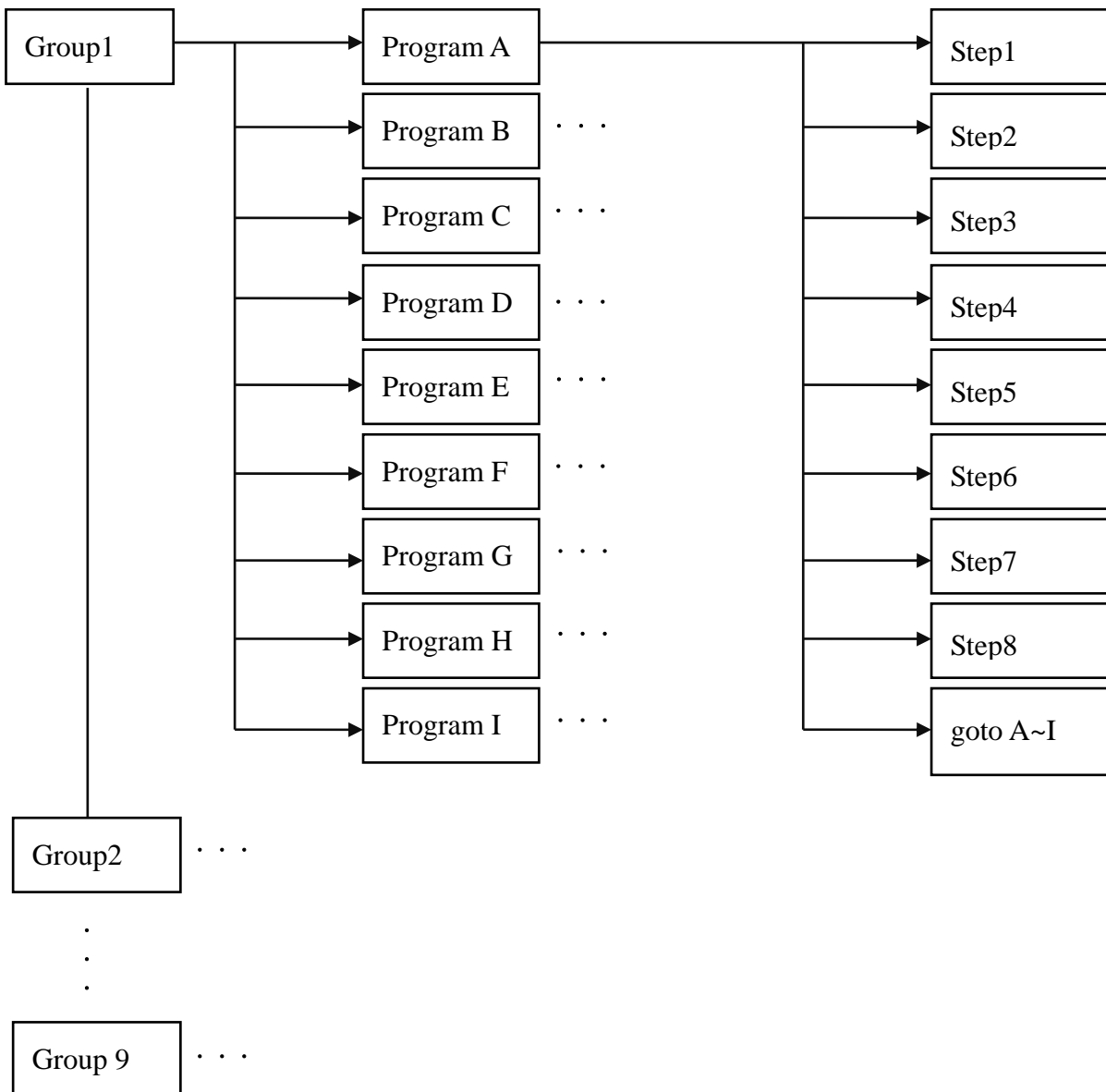



Group structure:

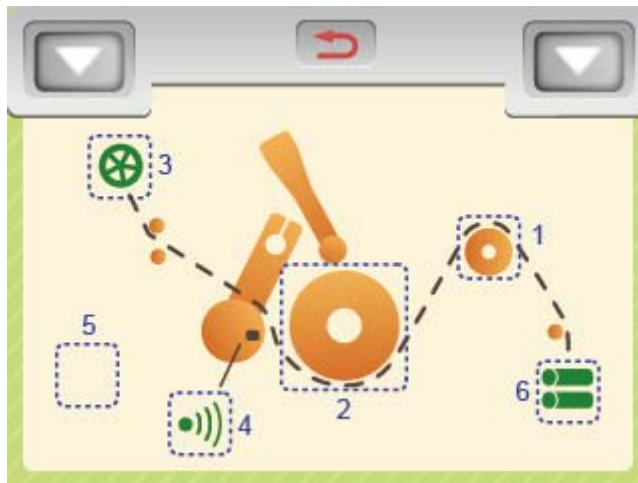

5. Testing mode

Press  at left side menu to enter the Testing mode, the following menu is shown.

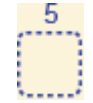

Icon	Description	Icon	Description
	Reserved.		Tape thickness detector settings.
	Driven Roller test.		Reserved.
	Untangling device settings.		Accessory test.

5-1. Driven roller test

Press  to enter the driven roller test menu as shown below.

Caution: Ensure that no tape is on the driven roller.



Step 1. Press  and the driven roller will run clockwise for 2 seconds.

Step 2. Press  and the driven roller will run counterclockwise for 2 seconds.

5-2. Untangling device setting mode

Press  to enter the untangling setting mode. There are 3 possible sub modes in this mode.

5-2-1. Off mode: Untangling device stops working.

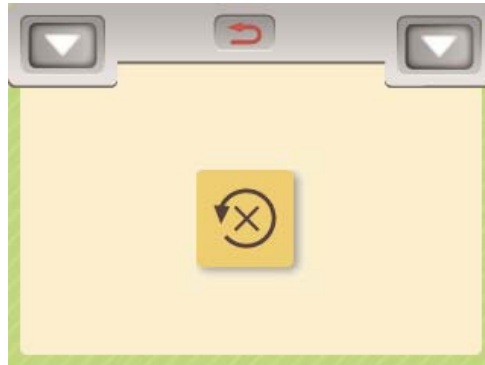

5-2-2. Synchronous mod: The driven roller rotates synchronously with the untangling device.

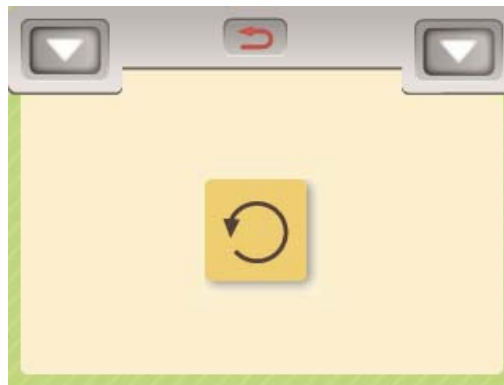

5-2-3. Intermittent mode: Press On/OFF to pop up the keyboard, then enter the seconds for ON/OFF the untangling device.

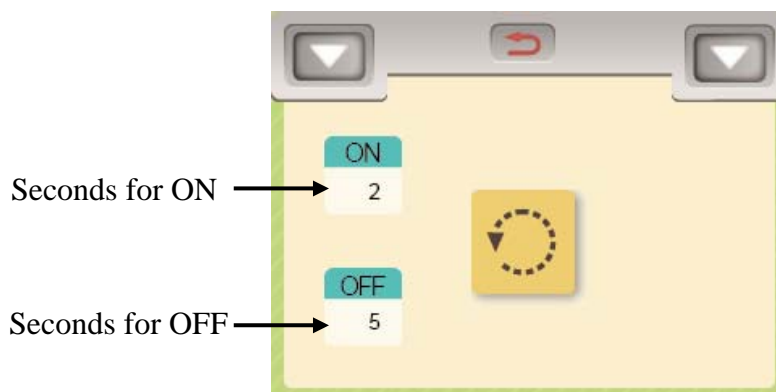



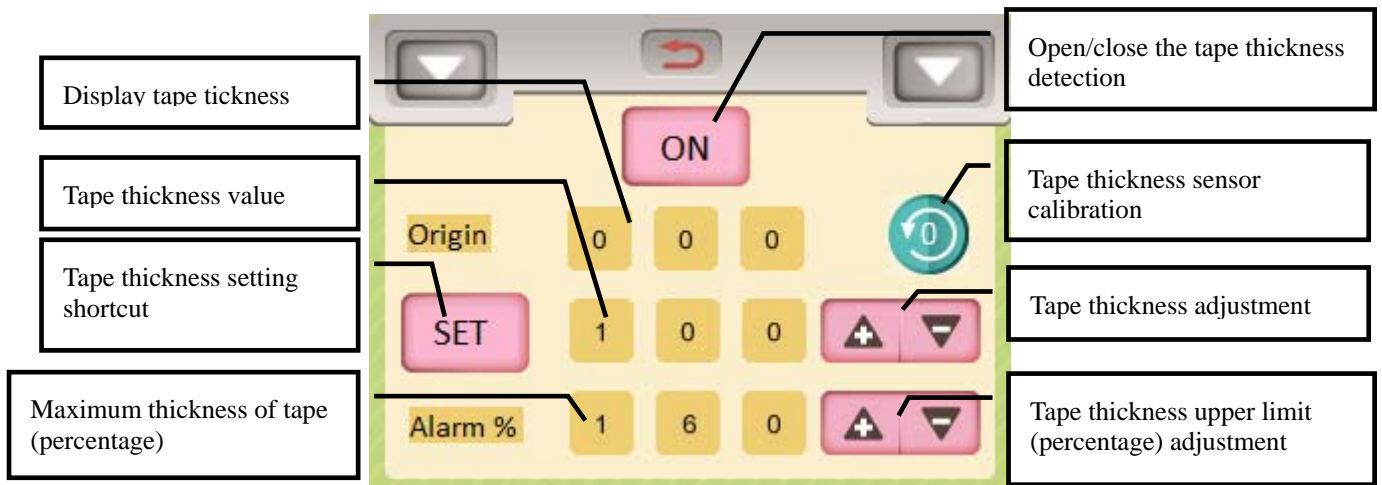

5-3. Thickness detecting mode

Press  to enter the Thickness detecting mode.



The setting steps are as follows:

- Step 1. Press .
- Step 2. Remove any tape from the driven roller and the auxiliary roller, then close the auxiliary roller handler. The value of thickness (Origin) should read between -5~+5. If the value of thickness is incorrect, refer to Step 3 for performing the calibration of thickness detecting sensor.
- Step 3. Press <Tape thickness sensor calibration>, menu shows. "N074:tape thickness sensor calibration OK". The value of thickness should read between -5~+5.
- Step 4. Place the tape over the driven roller and the auxiliary roller to get the value of tape thickness.
- Step 5. Press  to copy the tape thickness to  .
- Step 6. The alarm setting can be set to a maximum thickness of 200% and the system alarm "E075" alerts when the thickness of tape exceeds the maximum setting.

5-4. Accessory test

Press  to enter the Accessory test mode for the optional device.



Description of Accessory test:







5-4-1.  Reserved

5-4-2.  Reserved

5-4-3.  Reserved

5-4-4.  Reserved

5-4-5.  External switch and state display.
Used for an external switch activation status display.

Display	Description
	No external switch in use
	Used for an external knee switch activation status display
	Used for external Step change switch activation status display
	Presser foot lifter switch activation status display used at pedal toeing down.
	Presser foot lifter switch activation status display used at pedal heeling down.
	TK safety switch activation status display.
	Free tension switch activated status display.

5-4-6.  Reserved

5-4-7.  TK device test mode:
Press the key, rear cutter will cut the tape. (The function requires TK device installed.)

NO	Parameter	Preset value	Range	Description
36	ASL s-on sti	0	0~99	Stitches for ASL while the sensor detect the fabric front.
37	ASL s-off sti	0	0~99	Stitches for ASL while the fabric tail left the sensor.
43	pedal emg stop func	On	Off / On	Pedal heeling down for emergency stop in automatic sewing mode.
44	TK end cutter stop	onup	off/on/onup	End stop at TK rear tape cut: off: sewing machine does not stop after tape rear cut. on: sewing machine stops after rear tape cut. onup: sewing machine stops after rear tape cut and needle up.
45	sewing counter	0	0~9999	Counter setting.
46	synchronizer	inst	noth / inst	Synchronizer(optional), noth: With sync., inst: Without sync.
54	fabric protection	off	off/s/m/sm	Fabric protection switch: off: Disable. s: TK device is prohibited to act when the sensor detects fabric(note.1) m: TK device is prohibited to act when servo motor is running sm: Comprises both functions of s and m.
57	fabric sensor type	L.ON	off/L.ON /D.ON	Sensor type setting(optional): off: Disable D.ON: Dark-ON mode L.ON: Light-ON mode
58	mesh counter	0	0~99	Mesh width setting (unit: stitch)

Note 1: The function requires TK device installed.

6-1.Restore default setting

The procedure to restore default settings is described as follows:

Step 1. Press  at left menu to enter restore default setting page.

Step 2. Shift the selection bar to 18.

Step 3. Press '+' to pop up the following dialog box menu.

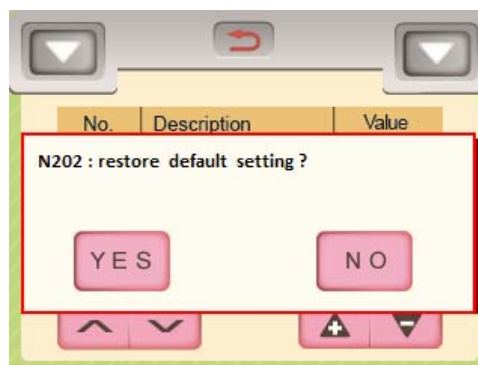

Step 4. Press "YES", then a prompt code shows "N099:Please reboot".

Step 5. Turn the power OFF then ON, the default settings are restored.

6-2. Setting needle Up/Down position at machine stop

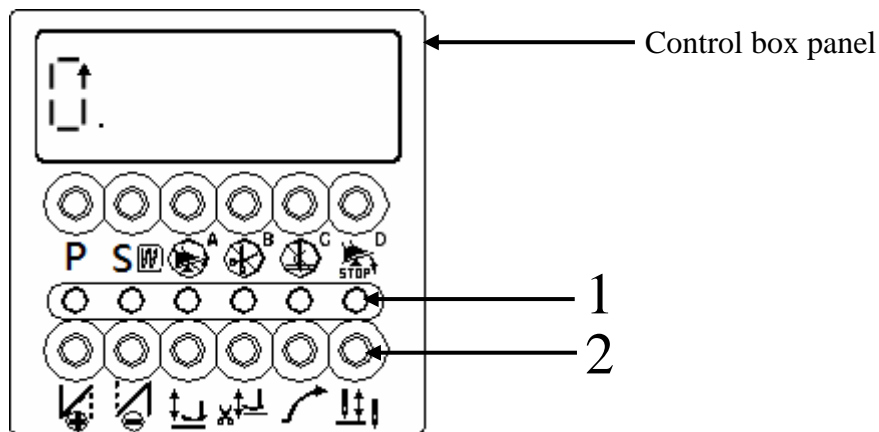

[Setting instruction]





Needle stops at Down position: Press Button 2 and ensure that Light 1 is OFF.

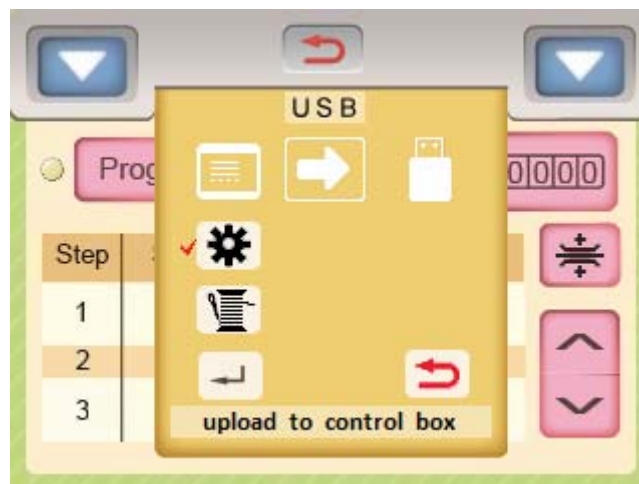

Needle stops at Up position: Press Button 2 and ensure that Light 1 is ON.

7. USB upload/download

Press  at left side menu to enter USB upload/download page.



Icon	Description
	Press to select upload or download.  Upload: Upload the parameter or Program data from USB flash drive to MCU.  Download: Download the parameter or Program data from MCU to USB flash drive.
	Parameter data: Press this key, then a check mark will appear with it. The Upload/Download action includes parameter data.

Icon	Description
	Group data: Press this key, then a check mark will appear with it. The Upload/Download action includes the data of 9 selectable groups.
	Press to start Upload/Download.
	Return to the Sewing mode menu.

7-1. Download:

The procedure to download the parameter and Program data from MCU to USB flash drive is described as follows:

Step 1. Select download mode.

Step 2. Plug a USB flash drive to Control box and make a beep.

Step 3. Press  to check mark and to enable the download of parameter settings.

Step 4. Press  1 ~ 9 to check mark and to enable the download data of 9 selectable groups.

The menu is shown as below.

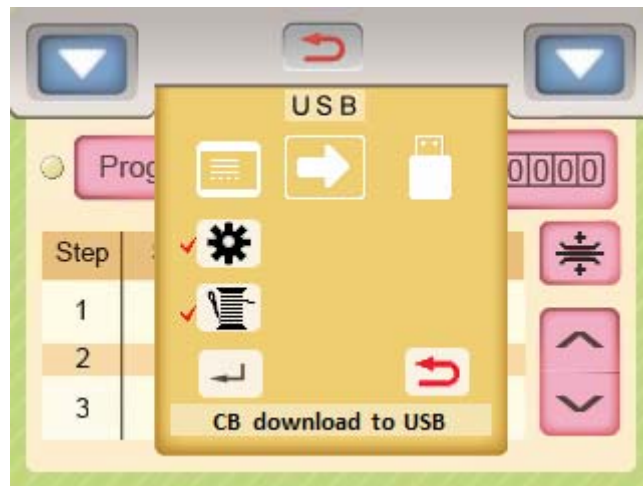

Step 5. Press  to pop up the dialog box menu as shown. Press "YES" to download the parameter settings and Program data from MCU to the USB flash drive. The parameter file "TCPARAME.TCD" and the Program data file "TCPROCES.TCD" will be stored in the root directory of the USB flash drive.

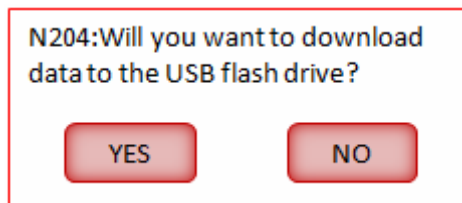

Step 6. The following prompt message shown on the menu indicates the completion of Download operation.

N045:Control box params download to USB OK.

N047:Control box sewing data download to USB OK.

NOTE: If The parameter file "TCPARAME.TCD" and the Program data file "TCPROCES.TCD" exist in the root directory of the USB flash drive before Download operation, "TCPARAME.TCD" will be saved as "TCPARME.BA1" and "TCPROCES.TCD" will be saved as "TCPROCES.BA1". Next, the new Download operation can proceed.

7-2. Upload:

The procedure to upload the parameter and Program data from USB flash drive to MCU is described as follows:

Step 1. Select Upload mode.

Step 2. Plug a USB flash drive to Control box and make a beep.

Step 3. Touch  to check mark and to enable the upload of parameter settings..

Step 4. Touch  to check mark and to enable the upload data of 9 selectable groups.

The menu is shown as below.

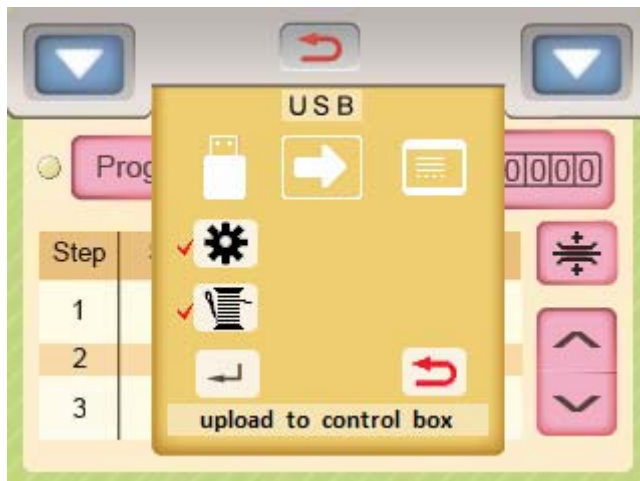

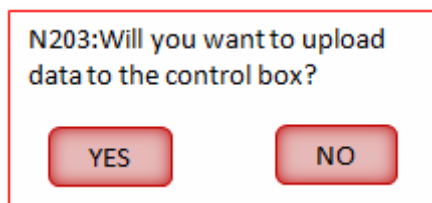

Step 5. Press  to pop up the dialog box menu as shown. Press "YES" to upload the parameter settings and Program data from the USB flash drive to MCU. The parameter file "TCPARAME.TCD" and the Program data file "TCPROCES.TCD" stored in the root directory of the USB flash drive will be uploaded to MCU.



Step 6. The following prompt message shown on the menu indicates the completion of upload operation.

N044:USB params Upload to control box OK.Please reboot.

N046:USB sewing data upload to control box OK.please reboot.

NOTE:  disappears automatically if the parameter file "TCPARAME.TCD" is not in the root directory of the USB flash drive; similarly,  disappears automatically if the parameter file "TCPROCES.TCD" is not in the root directory of the USB flash drive.

8.Operation instruction

Example 1: Single step program with the tension value 700.

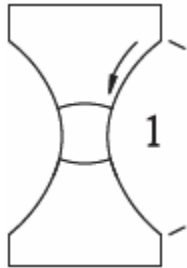

Tension value=700

The procedure is illustrated as follows:

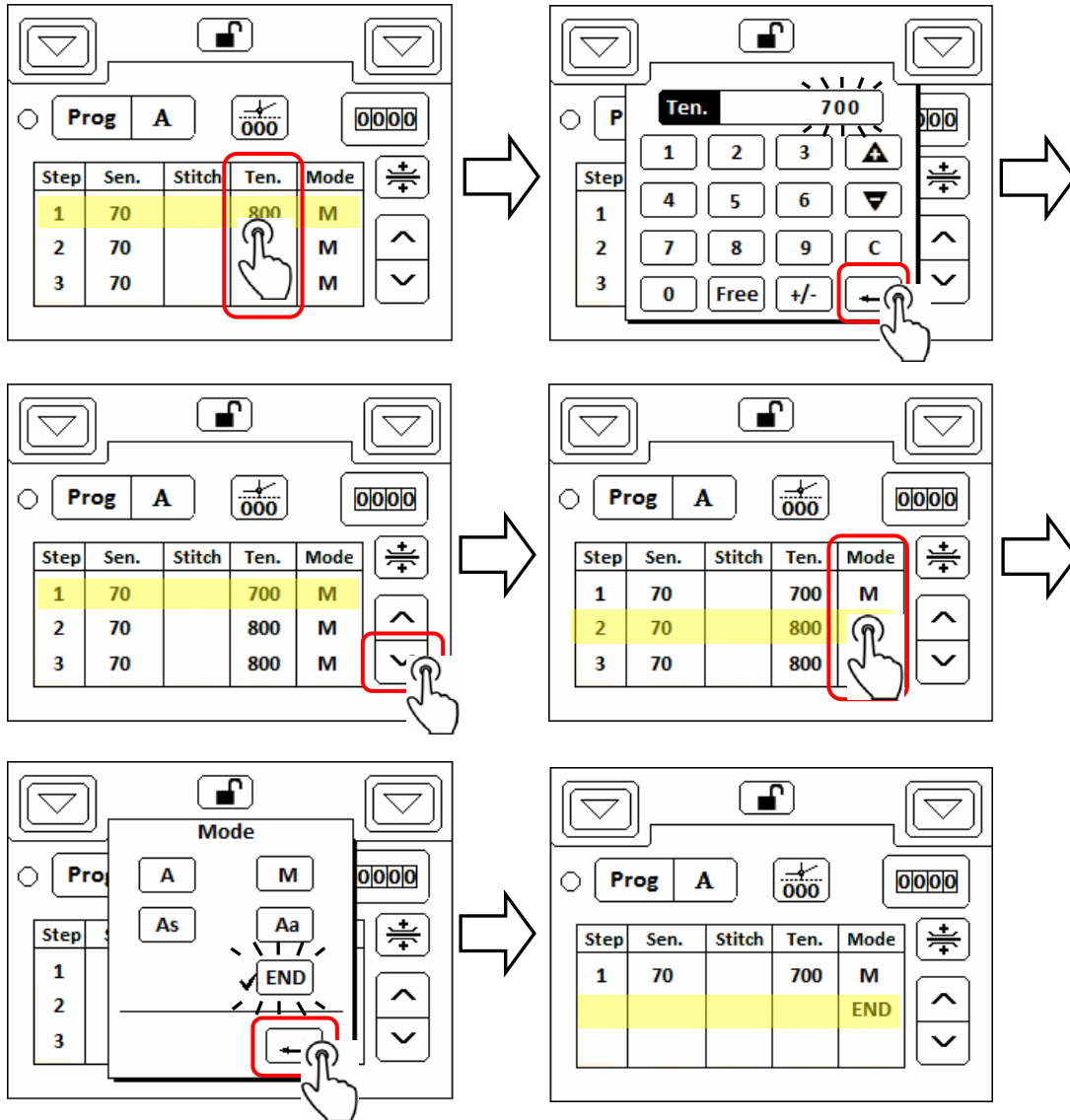

Comparison of tension values adjusted:

A small tension value

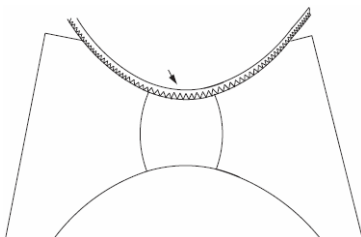

A large tension value

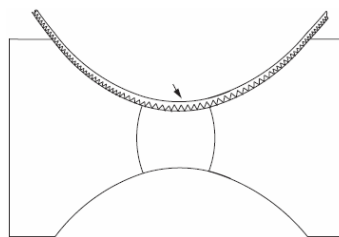

Example 2: Program of 2 steps changed automatically with the tension values and stitches set as shown.

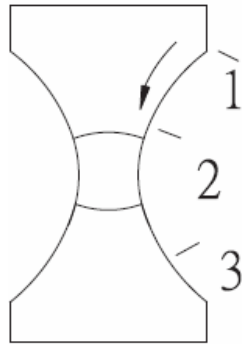

1 Tension value=700, stitch=100

2 Tension value=600, stitch=120

3 Tension value=800

The procedure is illustrated as follows:

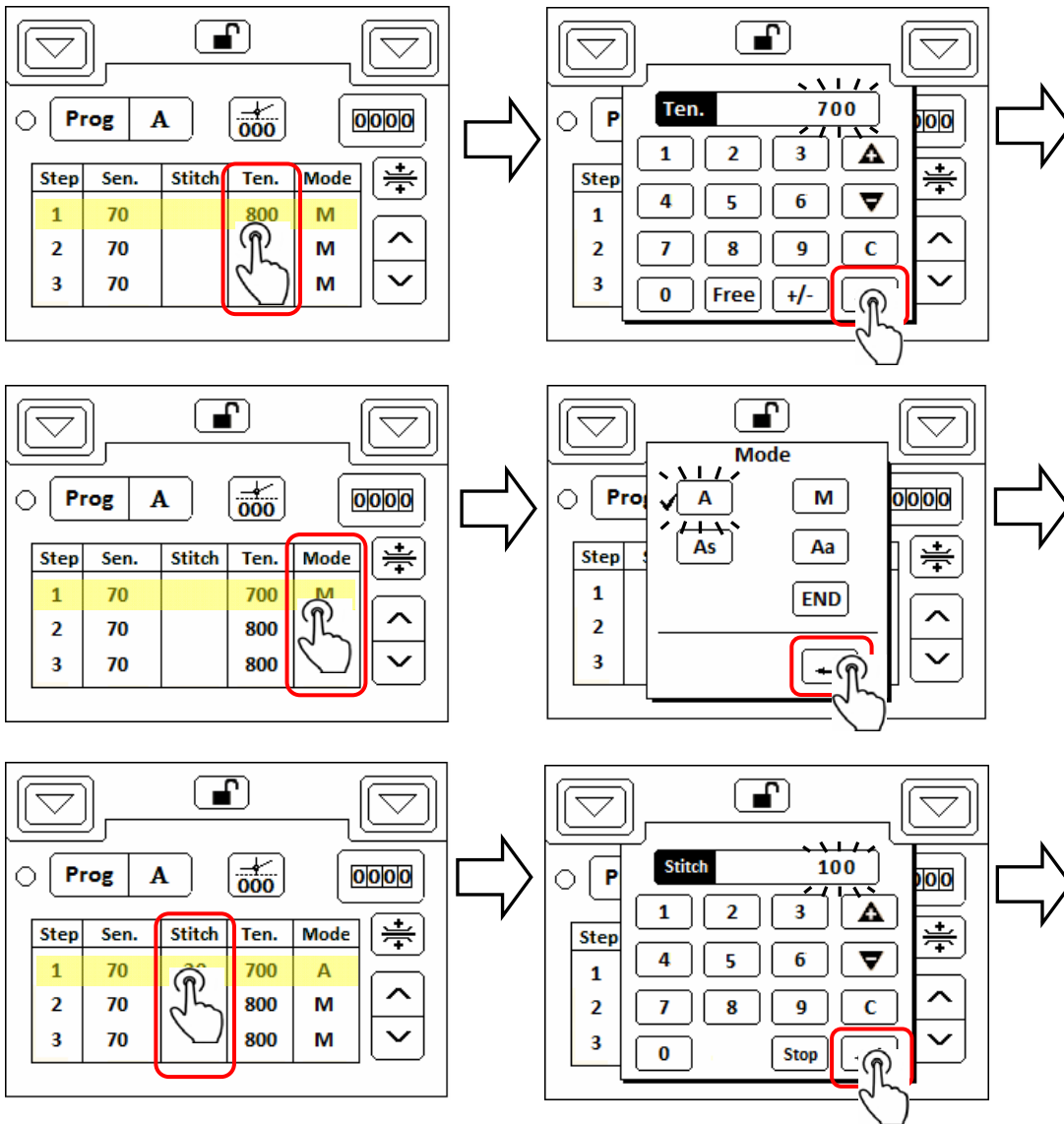

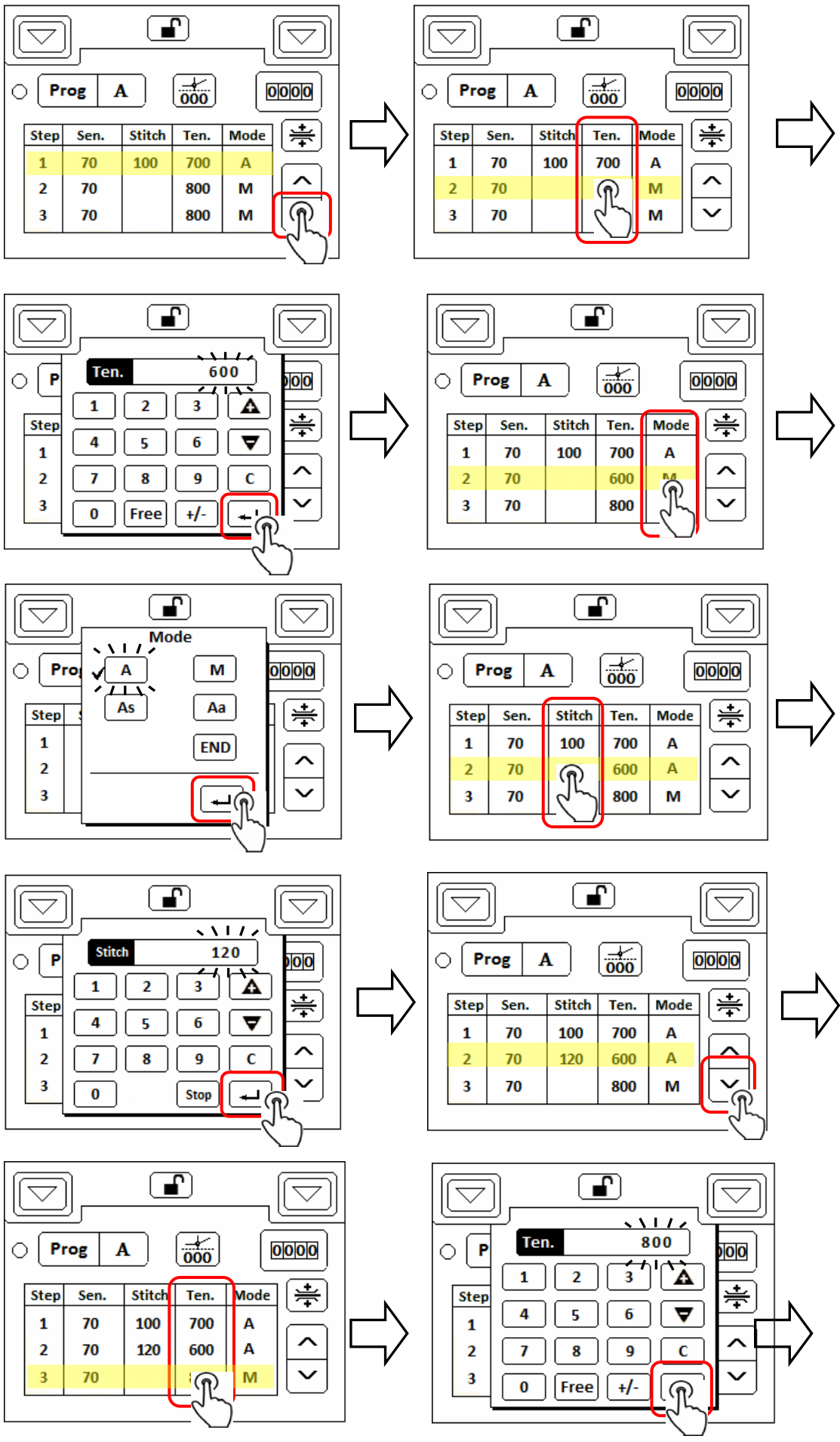

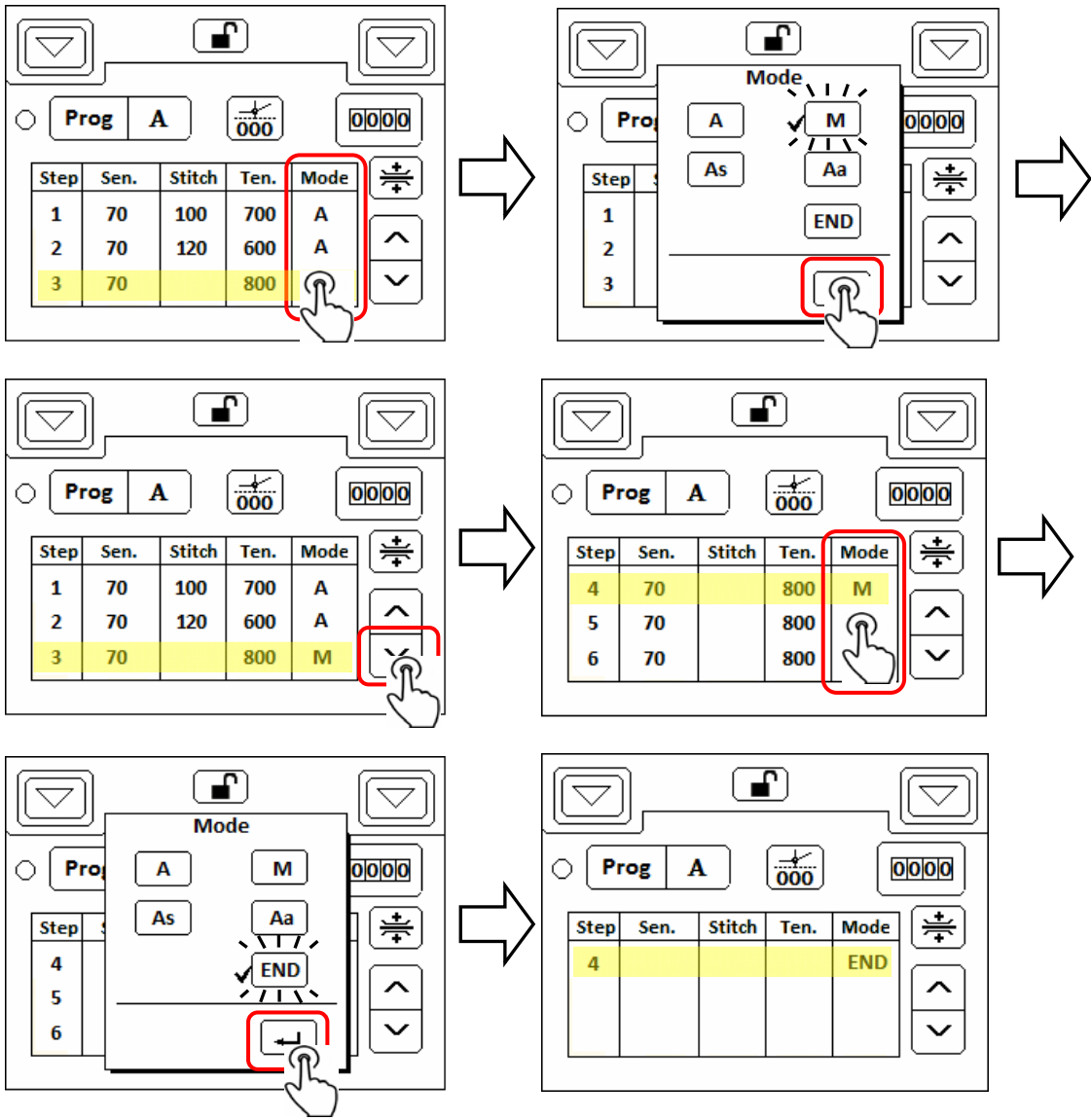

Example 3: Program of 3 steps is designed as shown.

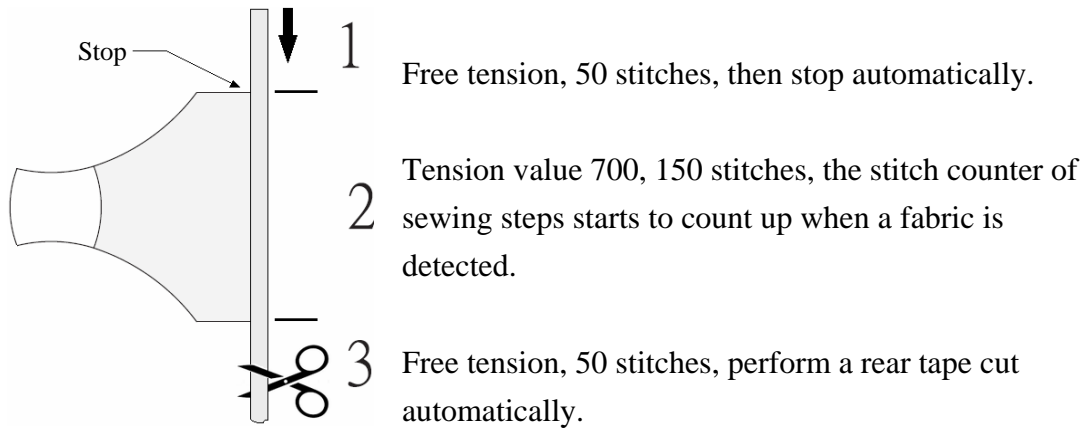

The procedure is illustrated as follows:

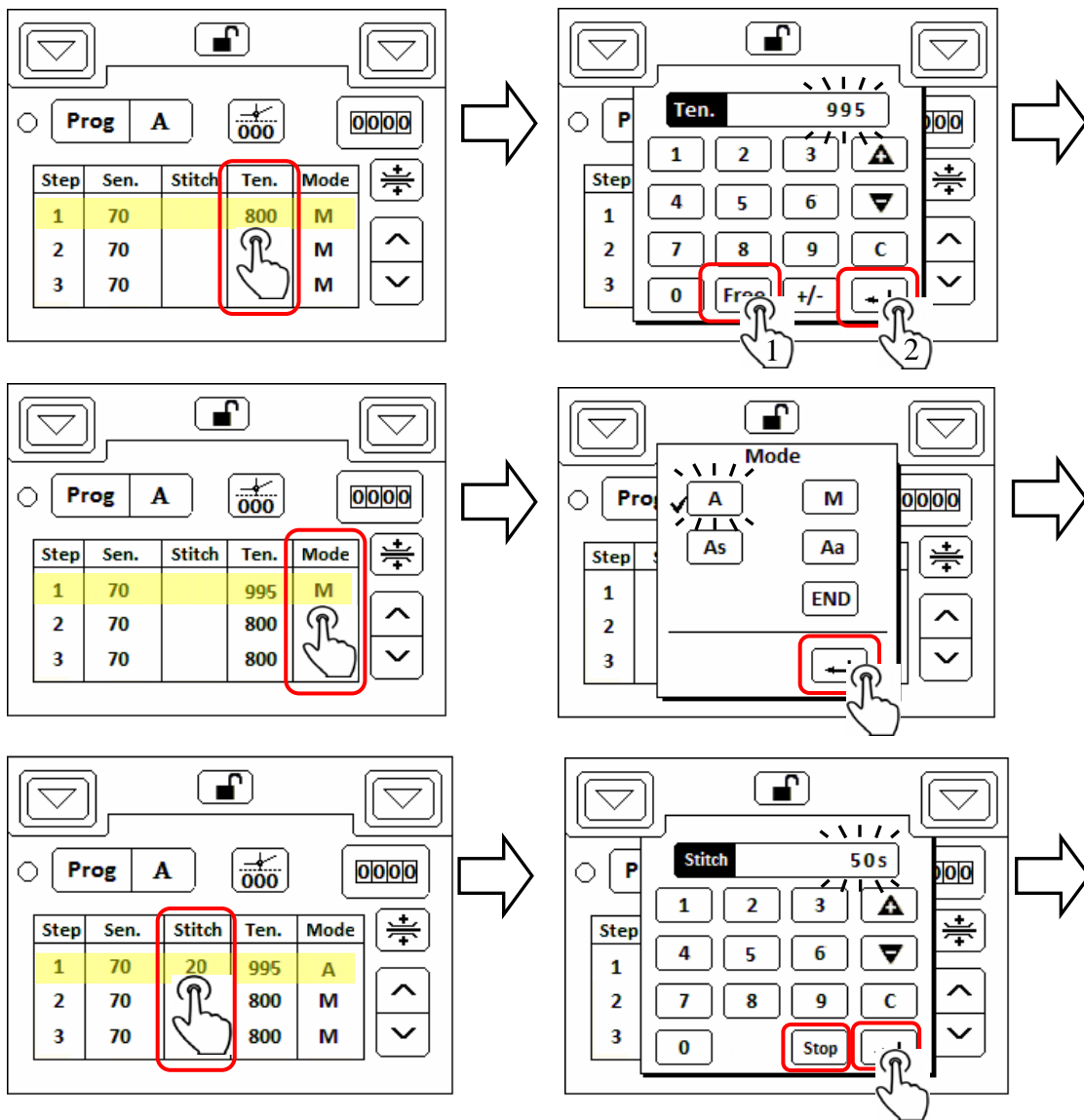

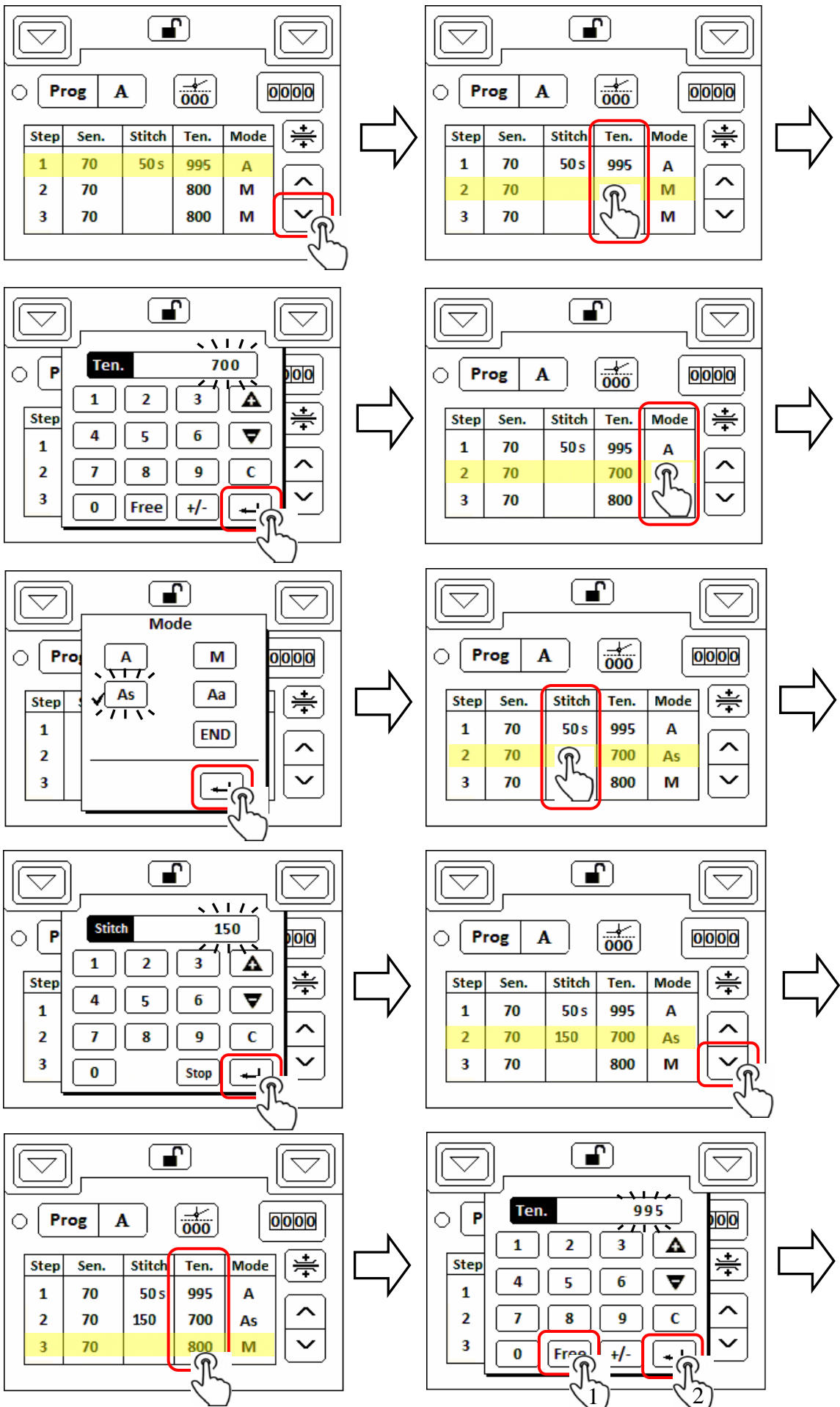

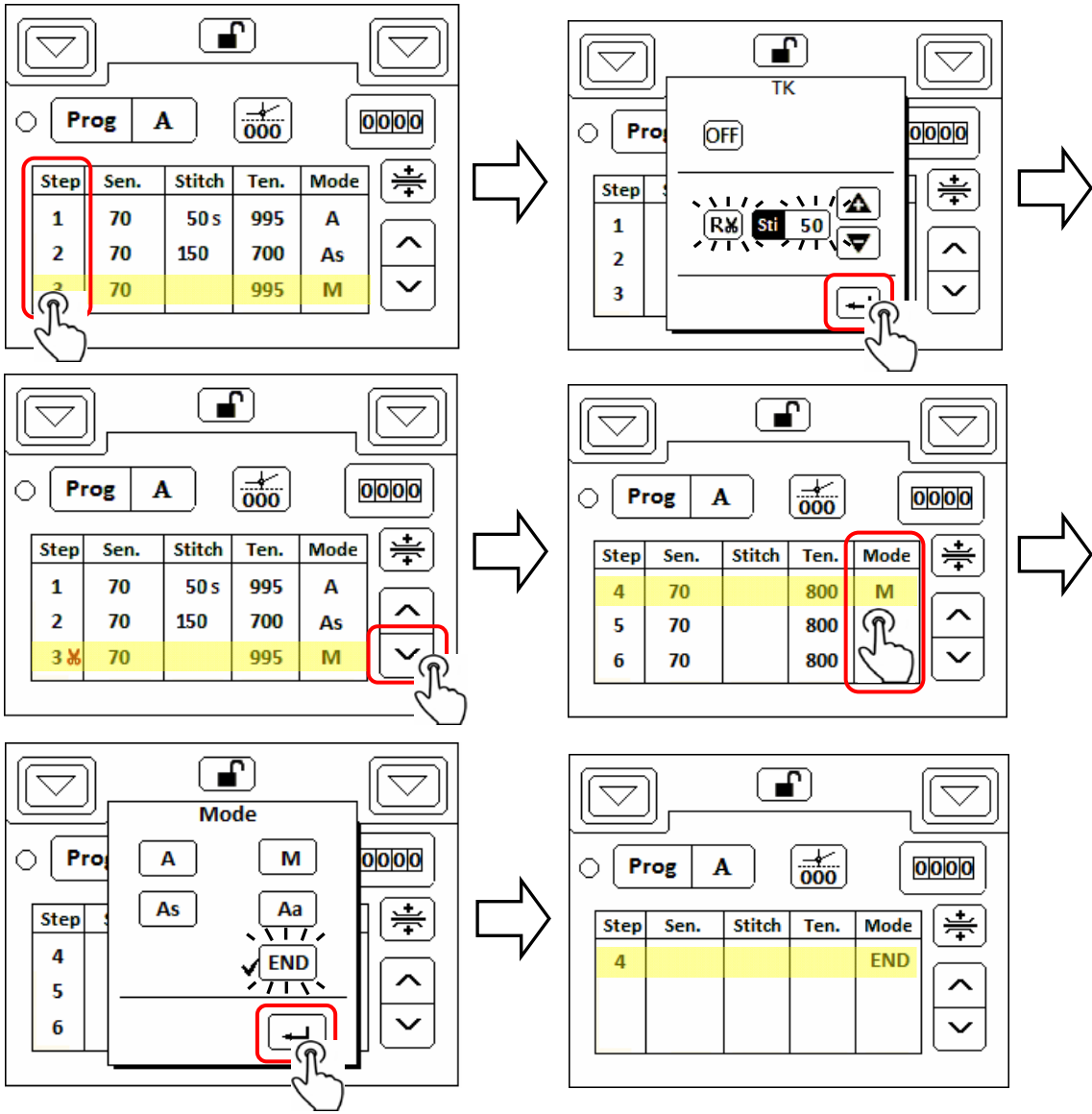

9. Prompt code and error code

9-1. Prompt code

Prompt codes are Arabic numerals with a character 'N' at the beginning. There are used to prompt user the next action to do or the feedback message from the previous action.

Code	Prompt message	Description
N044	USB params Upload to control box OK.Please reboot.	USB parameters upload to control box is successful .
N045	Control box params download to USB OK	Control box parameters download to USB is successful.
N046	USB sewing data upload to control box OK.please reboot.	USB Program data upload to control box is successful.
N047	Control box sewing data download to USB OK	Control box Program data download to USB is successful.
N064	Load cell calibration OK	Load cell 0kg calibration is successful.
N065	Load cell calibration OK	Load cell 1.8kgs calibration is successful. Please remove the 1.8kgs weight.
N066	Pls remove tape and weights on the load cell then press any key...	Please remove the fabric and weights on the load cell, then press any key.
N067	Pls hang 1.8KG of weights on the load cell then press any key...	Please hang the 1.8 kg weight onto the load cell.
N074	tape thickness sensor calibration OK	Tape thickness sensor calibration is successful.
N076	Pls remove tape on the auxiliary roller and handle bar back to original position then press any key...	Please remove any tape on the auxiliary roller and handler back to original position, and then press any key...
N098	Save parameters ok	Restoring the default setting is successful.
N099	Please reboot	Turn the power OFF, then turn it ON.
N200	Reset system? all params will be lost	Confirm message for "Reset".
N201	Power Off	Power off.
N202	restore default setting?	Confirm message for "restore". Press "YES" to restore the default value.
N203	Will you want to upload data to the control box?	Confirm message for "upload". Press "YES" to upload.
N204	Will you want to download data to the USB flash drive?	Confirm message for "download". Press "YES" to download.
N205	Auxiliary roller handle is opened	Auxiliary roller handler is opened.

9-2. Error code

Error codes are Arabic numerals with a character 'E' at the beginning. There are used to alert user the system malfunctions occur. Further actions should be taken to conduct the troubleshooting.

Code	Error and failure	Troubleshooting
E040	USB params upload to control box failure	<p>USB parameter upload to control box is failed.</p> <ol style="list-style-type: none"> 1. Unplug and replug the USB flash drive.. 2. Use a new USB flash drive. 3. Check if the parameter file "TCPARAME.TCD" is damaged.
E041	Control box params download to USB failure	<p>Control box parameter download to USB is failed.</p> <ol style="list-style-type: none"> 1. Unplug and replug the USB flash drive. 2. Check if the storage capacity of USB flash drive is insufficient. 3. Use a new USB flash drive.
E042	USB sewing data upload to control box failure	<p>USB Program data upload to control box is failed.</p> <ol style="list-style-type: none"> 1. Unplug and replug the USB flash drive. 2. Use a new USB flash drive. 3. Check if the Program data file "TCPROCES.TCD" is damaged.
E043	Control box sewing data download to USB failure	<p>Control box Program data download to USB is failed.</p> <ol style="list-style-type: none"> 1. Unplug and replug the USB flash drive. 2. Check if the storage capacity of USB flash drive is insufficient. 3. Use a new USB flash drive.
E050	memory read error	Ask a qualified technician.
E051	memory write error	Ask a qualified technician.
E052	Calibration value read error	Check the cable connection between Control box and Tension device.
E053	Calibration value write error	Check the cable connection between Control box and Tension device.
E060	Load cell calibration fail	Check the cable connection between Control box and Tension device.
E061	Load cell calibration fail	<p>Load cell free calibration failed.</p> <ol style="list-style-type: none"> 1. Check the cable connection between Control box and Tension device.. 2. Remove the tape on load cell.
E062	Load cell calibration fail	<p>Load cell 1.8kg calibration failed.</p> <ol style="list-style-type: none"> 1. Check the cable connection between Control box and Tension device.. 2. Hang the 1.8Kg weight on load cell.. 3. Ensure no mechanical obstacle of load cell movement.
E063	Read tension fail	Check the cable connection between Control box and Tension device.
E071	tape thickness sensor calibration fail	<ol style="list-style-type: none"> 1. Check the cable connection between Control box and Tension device. 2. Remove the tape on the auxiliary roller. 3. Close the handler of untangling device.
E073	Read tape thickness fail	Check the cable connection between Control box and Tension device.
E075	Detect abnormal thickness of the tape	<ol style="list-style-type: none"> 1. Ensure that the tape is properly winding around the Driven and Auxiliary roller. 2. Check if a correct value is set (refer to 5-4.)

Code	Error and failure	Troubleshooting
E077	Load cell overload warning	<ol style="list-style-type: none"> 1. Ensure that the tape is properly winding around the Driven and Auxiliary roller. 2. Increase the setting value of parameter 11.
E100	TP and MB link fail	Check the cable connection between Control box and Touch panel.

All rights reserved
Violators will be prosecuted